

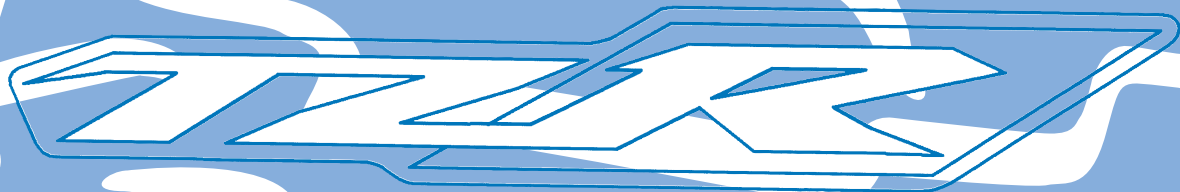

OWNER'S MANUAL



TZR50

5WX-F819D-E2

Welcome to the Yamaha world of motorcycling!

As the owner of the TZR50, you are benefiting from Yamaha's vast experience and newest technology regarding the design and manufacture of high-quality products, which have earned Yamaha a reputation for dependability.

Please take the time to read this manual thoroughly, so as to enjoy all advantages of your TZR50. The owner's manual does not only instruct you in how to operate, inspect and maintain your motorcycle, but also in how to safeguard yourself and others from trouble and injury.



In addition, the many tips given in this manual will help keep your motorcycle in the best possible condition. If you have any further questions, do not hesitate to contact your Yamaha dealer.

The Yamaha team wishes you many safe and pleasant rides. So, remember to put safety first!

IMPORTANT MANUAL INFORMATION

EAU10151

Particularly important information is distinguished in this manual by the following notations:

	The Safety Alert Symbol means ATTENTION! BECOME ALERT! YOUR SAFETY IS INVOLVED!
 WARNING	Failure to follow WARNING instructions <u>could result in severe injury or death</u> to the motorcycle operator, a bystander, or a person inspecting or repairing the motorcycle.
CAUTION	A CAUTION indicates special precautions that must be taken to avoid damage to the motorcycle.
NOTE:	A NOTE provides key information to make procedures easier or clearer.

NOTE:

- This manual should be considered a permanent part of this motorcycle and should remain with it even if the motorcycle is subsequently sold.
- Yamaha continually seeks advancements in product design and quality. Therefore, while this manual contains the most current product information available at the time of printing, there may be minor discrepancies between your motorcycle and this manual. If you have any questions concerning this manual, please consult your Yamaha dealer.

EWA10030

WARNING

PLEASE READ THIS MANUAL CAREFULLY AND COMPLETELY BEFORE OPERATING THIS MOTORCYCLE.

*Product and specifications are subject to change without notice.

IMPORTANT MANUAL INFORMATION

EAUS1172

**TZR50
OWNER'S MANUAL
©2006 by YAMAHA MOTOR ESPAÑA S.A.
2nd edition, October 2006.
All rights reserved.
Any reprinting or unauthorized use
without the written permission of
YAMAHA MOTOR ESPAÑA S.A.
is expressly prohibited.
Printed in Neederland.**

TABLE OF CONTENTS

SAFETY INFORMATION	1-1	PRE-OPERATION CHECKS	4-1	Checking the front brake lever free	
DESCRIPTION	2-1	Pre-operation check list.....	4-2	play	6-17
Left view	2-1	OPERATION AND IMPORTANT RIDING		Adjusting the brake pedal free	
Right view	2-2	POINTS	5-1	play	6-17
Controls and instruments	2-3	Starting a cold engine	5-1	Adjusting the shift pedal position ..	6-18
INSTRUMENT AND CONTROL		Starting a warm engine	5-2	Adjusting the rear brake light	
FUNCTIONS	3-1	Shifting.....	5-2	switch	6-18
Main switch/steering lock.....	3-1	Tips for reducing fuel consumption..	5-3	Checking the front and rear brake	
Indicator and warning lights	3-1	Engine break-in.....	5-3	pads.....	6-18
Speedometer unit	3-2	Parking.....	5-4	Checking the brake fluid level	6-19
Tachometer	3-3	PERIODIC MAINTENANCE AND		Changing the brake fluid	6-20
Handlebar switches	3-3	MINOR REPAIR	6-1	Drive chain slack.....	6-21
Clutch lever.....	3-4	Owner's tool kit.....	6-1	Cleaning and lubricating the drive	
Shift pedal.....	3-4	Periodic maintenance and		chain.....	6-22
Brake lever.....	3-5	lubrication chart	6-2	Checking and lubricating the	
Brake pedal.....	3-5	Removing and installing cowlings		cables	6-23
Fuel	3-5	and panels.....	6-5	Checking and lubricating the	
Catalytic converter.....	3-6	Checking the spark plug	6-7	throttle grip and cable.....	6-23
Fuel tank cap	3-6	Transmission oil	6-8	Adjusting the Autolube pump.....	6-24
Fuel tank breather/overflow hose.....	3-7	Coolant	6-9	Checking and lubricating the brake	
2-stroke engine oil	3-7	Air filter element.....	6-12	and shift pedals.....	6-24
Fuel cock	3-8	Adjusting the carburetor	6-12	Checking and lubricating the brake	
Starter (choke) lever “ ”.....	3-8	Adjusting the throttle cable free		and clutch levers.....	6-24
Seat.....	3-9	play	6-12	Checking and lubricating the	
Anti-theft device housing.....	3-9	Adjusting the engine idling speed ..	6-13	sidestand.....	6-25
Rear view mirrors.....	3-9	Tires	6-14	Checking the front fork.....	6-25
Sidestand.....	3-10	Cast wheels	6-16	Checking the steering.....	6-26
Ignition circuit cut-off system	3-10	Adjusting the clutch lever free		Checking the wheel bearings	6-26
		play	6-16	Battery	6-27
				Replacing the fuse.....	6-28
				Replacing the headlight bulb.....	6-28

TABLE OF CONTENTS

Replacing the license plate light bulb	6-29
Replacing a turn signal light bulb or the tail/brake light bulb	6-30
Replacing a front turn signal light bulb	6-30
Troubleshooting	6-31
Troubleshooting charts	6-32

MOTORCYCLE CARE AND

STORAGE	7-1
Care	7-1
Storage	7-3

SPECIFICATIONS	8-1
-----------------------------	-----

CONSUMER INFORMATION	9-1
Identification numbers	9-1

SAFETY INFORMATION

1

EAU10251

MOTORCYCLES ARE SINGLE TRACK VEHICLES. THEIR SAFE USE AND OPERATION ARE DEPENDENT UPON THE USE OF PROPER RIDING TECHNIQUES AS WELL AS THE EXPERTISE OF THE OPERATOR. EVERY OPERATOR SHOULD KNOW THE FOLLOWING REQUIREMENTS BEFORE RIDING THIS MOTORCYCLE.

HE OR SHE SHOULD:

- OBTAIN THOROUGH INSTRUCTIONS FROM A COMPETENT SOURCE ON ALL ASPECTS OF MOTORCYCLE OPERATION.
- OBSERVE THE WARNINGS AND MAINTENANCE REQUIREMENTS IN THE OWNER'S MANUAL.
- OBTAIN QUALIFIED TRAINING IN SAFE AND PROPER RIDING TECHNIQUES.
- OBTAIN PROFESSIONAL TECHNICAL SERVICE AS INDICATED BY THE OWNER'S MANUAL AND/OR WHEN MADE NECESSARY BY MECHANICAL CONDITIONS.

Safe riding

- Always make pre-operation checks. Careful checks may help prevent an accident.
- This motorcycle is designed to carry the operator and a passenger.
- The failure of motorists to detect and recognize motorcycles in traffic is the predominating cause of automobile/motorcycle accidents. Many accidents have been caused by an automobile driver who did not see the motorcycle. Making yourself conspicuous appears to be very effective in reducing the chance of this type of accident.

Therefore:

- Wear a brightly colored jacket.
- Use extra caution when approaching and passing through intersections, since intersections are the most likely places for motorcycle accidents to occur.
- Ride where other motorists can see you. Avoid riding in another motorist's blind spot.

- Many motorcycle accidents involve inexperienced operators. In fact, many operators who have been involved in accidents do not even have a current motorcycle license.
 - Make sure that you are qualified and that you only lend your motorcycle to other qualified operators.
 - Know your skills and limits. Staying within your limits may help you to avoid an accident.
 - We recommend that you practice riding your motorcycle where there is no traffic until you have become thoroughly familiar with the motorcycle and all of its controls.
- Many motorcycle accidents have been caused by error of the motorcycle operator. A typical error made by the operator is veering wide on a turn due to EXCESSIVE SPEED or undercornering (insufficient lean angle for the speed).
 - Always obey the speed limit and never travel faster than

warranted by road and traffic conditions.

- Always signal before turning or changing lanes. Make sure that other motorists can see you.
- The posture of the operator and passenger is important for proper control.
- The operator should keep both hands on the handlebar and both feet on the operator footrests during operation to maintain control of the motorcycle.
- The passenger should always hold onto the operator, seat strap, or grab bar, if equipped, with both hands and keep both feet on the passenger footrests.
- Never carry a passenger unless he or she can firmly place both feet on the passenger footrests.
- Never ride under the influence of alcohol or other drugs.
- This motorcycle is designed for on-road use only, therefore, it is not suitable for off-road use.

Protective apparel

The majority of fatalities from motorcycle accidents are the result of head injuries. The use of a safety helmet is the single most critical factor in the prevention or reduction of head injuries.

- Always wear an approved helmet.
- Wear a face shield or goggles. Wind in your unprotected eyes could contribute to an impairment of vision which could delay seeing a hazard.
- The use of a jacket, heavy boots, trousers, gloves, etc., is effective in preventing or reducing abrasions or lacerations.
- Never wear loose-fitting clothes, otherwise they could catch on the control levers, footrests, or wheels and cause injury or an accident.
- Never touch the engine or exhaust system during or after operation. They become very hot and can cause burns. Always wear protective clothing that

covers your legs, ankles, and feet.

- Passengers should also observe the precautions mentioned above.

Modifications

Modifications made to this motorcycle not approved by Yamaha, or the removal of original equipment, may render the motorcycle unsafe for use and may cause severe personal injury. Modifications may also make your motorcycle illegal to use.

Loading and accessories

Adding accessories or cargo to your motorcycle can adversely affect stability and handling if the weight distribution of the motorcycle is changed. To avoid the possibility of an accident, use extreme caution when adding cargo or accessories to your motorcycle. Use extra care when riding a motorcycle that has added cargo or accessories. Here are some general guidelines to follow if loading cargo or adding accessories to your motorcycle:

Loading

The total weight of the operator, pas-

SAFETY INFORMATION

senger, accessories and cargo must not exceed the maximum load limit.

Maximum load:

196 kg (432.18 lb)

When loading within this weight limit, keep the following in mind:

- Cargo and accessory weight should be kept as low and close to the motorcycle as possible. Make sure to distribute the weight as evenly as possible on both sides of the motorcycle to minimize imbalance or instability.
- Shifting weights can create a sudden imbalance. Make sure that accessories and cargo are securely attached to the motorcycle before riding. Check accessory mounts and cargo restraints frequently.
- Never attach any large or heavy items to the handlebar, front fork, or front fender. These items, including such cargo as sleeping bags, duffel bags, or tents, can create unstable handling or slow steering response.

Accessories

Genuine Yamaha accessories have been specifically designed for use on this motorcycle. Since Yamaha cannot test all other accessories that may be available, you must personally be responsible for the proper selection, installation and use of non-Yamaha accessories. Use extreme caution when selecting and installing any accessories.

Keep the following guidelines in mind, as well as those provided under “Loading” when mounting accessories.

- Never install accessories or carry cargo that would impair the performance of your motorcycle. Carefully inspect the accessory before using it to make sure that it does not in any way reduce ground clearance or cornering clearance, limit suspension travel, steering travel or control operation, or obscure lights or reflectors.
- Accessories fitted to the handlebar or the front fork area can create instability due to improper weight distribution or

aerodynamic changes. If accessories are added to the handlebar or front fork area, they must be as lightweight as possible and should be kept to a minimum.

- Bulky or large accessories may seriously affect the stability of the motorcycle due to aerodynamic effects. Wind may attempt to lift the motorcycle, or the motorcycle may become unstable in cross winds. These accessories may also cause instability when passing or being passed by large vehicles.
- Certain accessories can displace the operator from his or her normal riding position. This improper position limits the freedom of movement of the operator and may limit control ability, therefore, such accessories are not recommended.
- Use caution when adding electrical accessories. If electrical accessories exceed the capacity of the motorcycle’s electrical sys-

tem, an electric failure could result, which could cause a dangerous loss of lights or engine power.

Gasoline and exhaust gas

- **GASOLINE IS HIGHLY FLAMMABLE:**
 - Always turn the engine off when refueling.
 - Take care not to spill any gasoline on the engine or exhaust system when refueling.
 - Never refuel while smoking or in the vicinity of an open flame.
- Never start the engine or let it run for any length of time in a closed area. The exhaust fumes are poisonous and may cause loss of consciousness and death within a short time. Always operate your motorcycle in an area that has adequate ventilation.
- Always turn the engine off before leaving the motorcycle unattended and remove the key from the main switch. When parking the motorcycle, note the following:
 - The engine and exhaust system may be hot, therefore,

park the motorcycle in a place where pedestrians or children are not likely to touch these hot areas.

- Do not park the motorcycle on a slope or soft ground, otherwise it may fall over.
- Do not park the motorcycle near a flammable source (e.g. a kerosene heater, or near an open flame), otherwise it could catch fire.
- When transporting the motorcycle in another vehicle, make sure that it is kept upright and that the fuel cock is turned to “ON” or “RES” (for vacuum type) / “OFF” (for manual type). If it should lean over, gasoline may leak out of the carburetor or fuel tank.
- If you should swallow any gasoline, inhale a lot of gasoline vapor, or allow gasoline to get into your eyes, see your doctor immediately. If any gasoline spills on your skin or clothing, immediately wash the affected area with soap and water and change your clothes.

DESCRIPTION

EAU10410

Left view

2

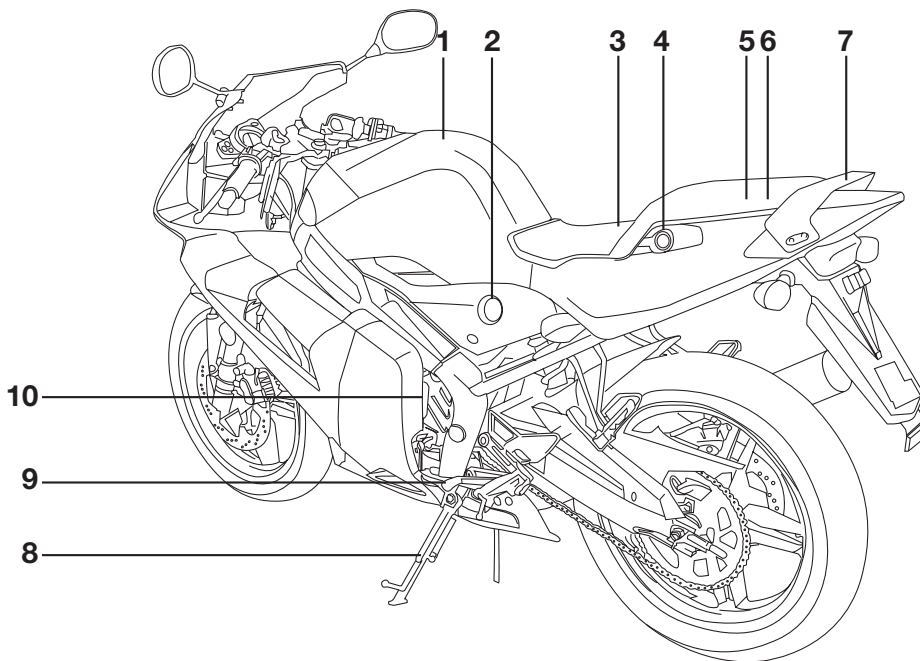

- 1. Fuel tank (page 3-6)
- 2. Fuel cock (page 3-8)
- 3. Oil tank (page 3-7)
- 4. Seat lock (page 3-9)
- 5. Battery/fuse box (page 6-27)

- 6. Owner's tool kit (page 6-1)
- 7. Grab bar
- 8. Sidestand (page 3-10)
- 9. Shift pedal (page 3-4)
- 10. Coolant recovery (page 6-9)

Right view

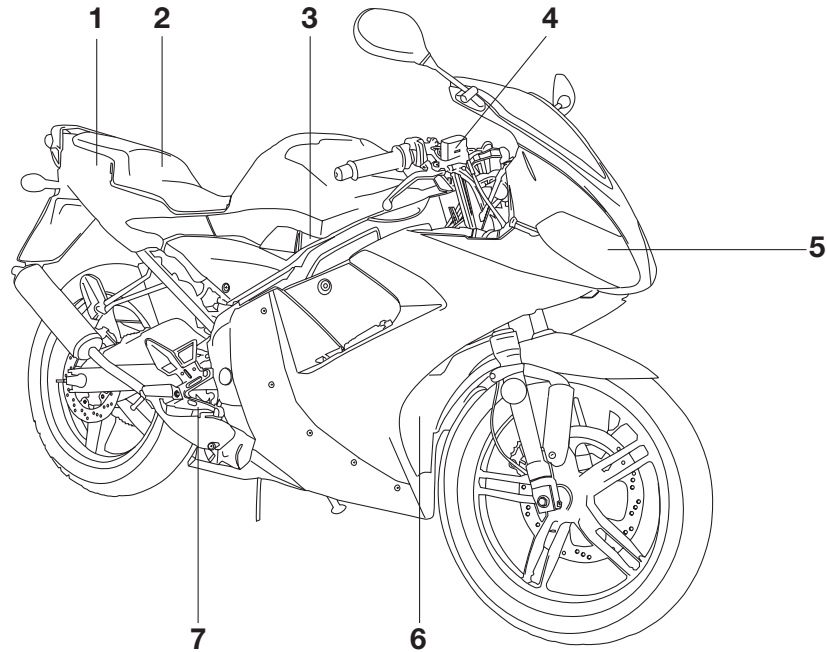

- 1. Storage compartment (page 3-9)
- 2. Seat (page 3-9)
- 3. Air filter (page 6-12)
- 4. Front brake fluid reservoir (page 6-19)

- 5. Headlight/Front turnal signal light (page 6-28)
- 6. Radiator (page 6-9)
- 7. Rear brake pedal (page 3-5)

DESCRIPTION

EAU10430

Controls and instruments

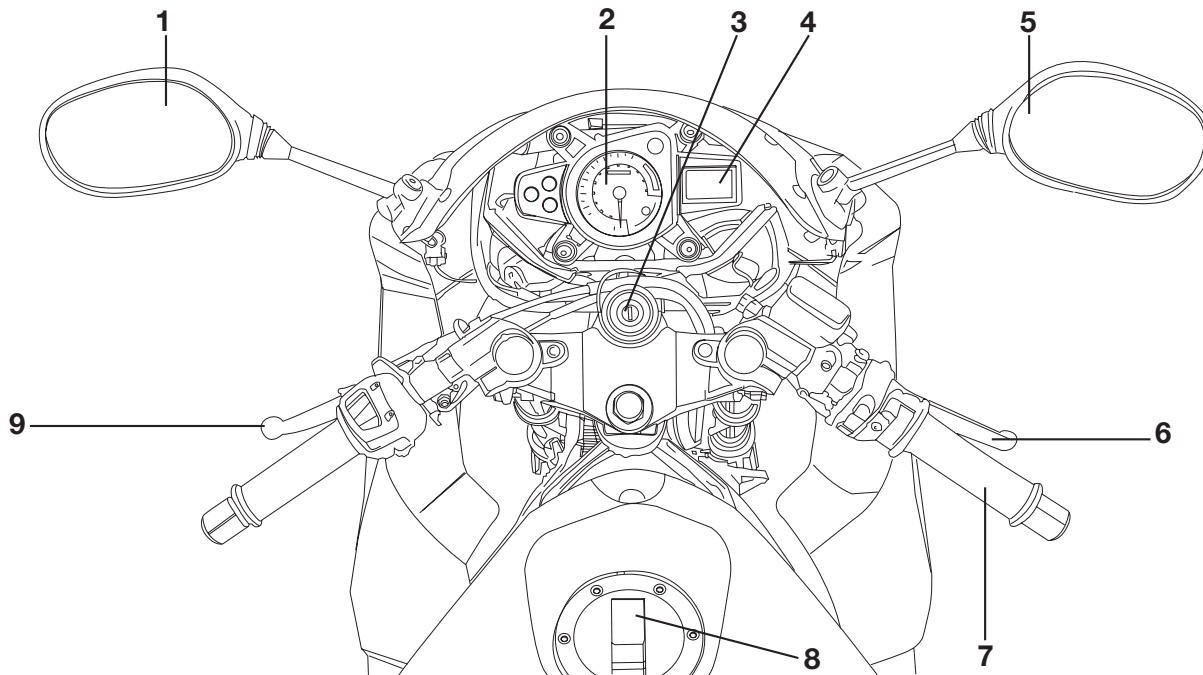

1. Left rear view mirror (page 3-9)

2. Tachometer (page 3-3)

3. Main switch/Steering lock (page 3-1)

4. Speedometer/Odometer (page 3-2)

5. Right rear view mirror (page 3-9)

6. Front brake lever (page 3-5)

7. Throttle grip (page 6-12)

8. Fuel tank cap (page 3-6)

9. Clutch lever (page 3-4)

INSTRUMENT AND CONTROL FUNCTIONS

Main switch/steering lock

EAU10460

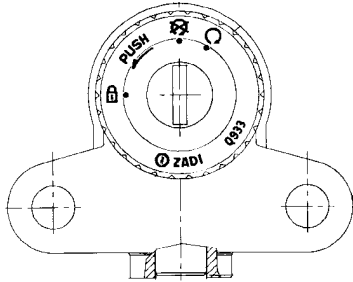

The main switch/steering lock controls the ignition and lighting systems, and is used to lock the steering. The various positions are described below.



All electrical circuits are supplied with power, and the engine can be started. The key cannot be removed.

NOTE:

The headlight, meter lighting and tail-light come on automatically when the engine is started.

EAU10640



All electrical systems are off. The key can be removed.

EAU10660



The steering is locked, and all electrical systems are off. The key can be removed.

EAU10680

To lock the steering

1. Turn the handlebars all the way to the left.
2. Push the key in from the “” position, and then turn it to “” while still pushing it.
3. Remove the key.

To unlock the steering

Push the key in, and then turn it to “” while still pushing it.

EWA10060

WARNING

Never turn the key to “” or “” while the vehicle is moving, otherwise the electrical systems will be switched off, which may result in loss of control or an accident. Make sure that the vehicle is stopped before turning the key to “” or “”.

Indicator and warning lights

EAU11003

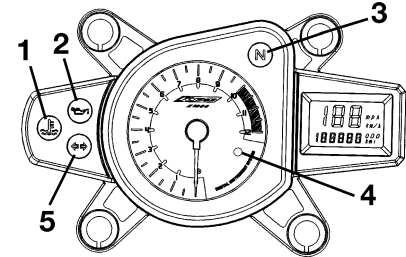

1. Coolant temperature warning light “”
2. Oil level warning light “”
3. Neutral indicator light “N”
4. Engine trouble warning light “”
5. Turn signal indicator light “”

EAU11020

Turn signal indicator light “”

This indicator light flashes when the turn signal switch is pushed to the left or right.

EAU11060

Neutral indicator light “N”

This indicator light comes on when the transmission is in the neutral position.

INSTRUMENT AND CONTROL FUNCTIONS

EAU11440

Coolant temperature warning light



This warning light comes on when the engine overheats. When this occurs, stop the engine immediately and allow the engine to cool.

The electrical circuit of the warning light can be checked by turning the key to “○”.

If the warning light does not come on for a few seconds, then go off, have a Yamaha dealer check the electrical circuit.

ECA10020

CAUTION:

Do not operate the engine if it is overheated.

EAUM1061

Oil level warning light



This warning light comes on when the key is in the “○” position or when the oil level in the 2-stroke engine oil tank is low during operation. If the warning light comes on during operation, stop immediately and fill the oil tank with 2-stroke engine oil of either JASO grade “FC” or ISO grades “EG-C” or “EG-D”. The warning light should go

off after the 2-stroke engine oil tank has been refilled.

NOTE:

If the warning light does not come on when the key is in the “○” position or does not go off after the 2-stroke engine oil tank has been refilled, have an Yamaha dealer check the electrical circuit.

ECA10010

CAUTION:

Do not operate the vehicle until you know that the engine oil level is sufficient.

EAU11500

Engine trouble warning light



This warning light comes on or flashes when an electrical circuit monitoring the engine is defective. When this occurs, have a Yamaha dealer check the self-diagnosis system.

The electrical circuit of the warning light can be checked by turning the key to “○”. If the warning light does not come on for a few seconds, then go off, have a Yamaha dealer check the electrical circuit.

EAU11621

Speedometer unit

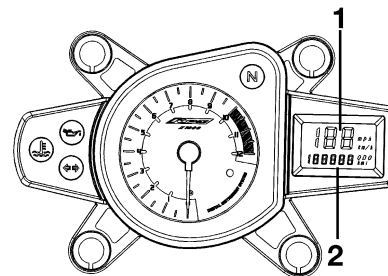

1. Speedometer
2. Odometer

The speedometer unit is equipped with a speedometer and an odometer. The speedometer shows riding speed. The odometer shows the total distance traveled.

INSTRUMENT AND CONTROL FUNCTIONS

EAU11851

Tachometer

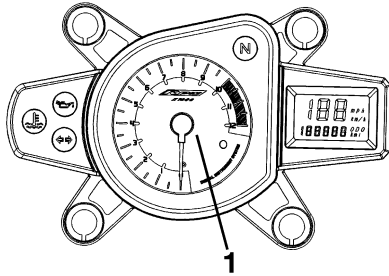

1. Tachometer

The electric tachometer allows the rider to monitor the engine speed and keep it within the ideal power range.

ECA10031

CAUTION:

Do not operate the engine in the tachometer red zone.

Red zone: 10.000 r/min and above

EAU12345

Handlebar switches

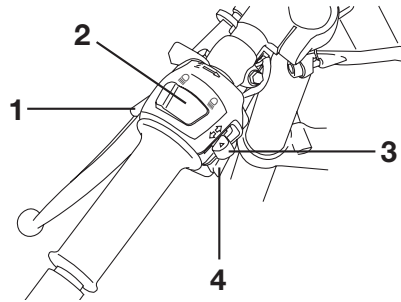

1. Pass switch “ $\equiv \text{D}$ ”
2. Dimmer switch “ $\equiv \text{D} / \text{D}$ ”
3. Turn signal switch “ $\blacktriangleleft / \blacktriangleright$ ”
4. Horn switch “ H ”

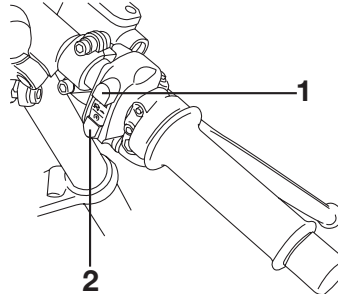

1. Engine stop switch “ O / X ”
2. Start switch “ O ”

EAU12380

Pass switch “ $\equiv \text{D}$ ”

Press this switch to flash the headlights.

EAU12400

Dimmer switch “ $\equiv \text{D} / \text{D}$ ”

Set this switch to “ $\equiv \text{D}$ ” for the high beam and to “ D ” for the low beam.

EAU12460

Turn signal switch “ $\blacktriangleleft / \blacktriangleright$ ”

To signal a right-hand turn, push this switch to “ \blacktriangleright ”. To signal a left-hand turn, push this switch to “ \blacktriangleleft ”. When released, the switch returns to the center position. To cancel the turn signal lights, push the switch in after it has returned to the center position.

EAU12500

Horn switch “ H ”

Press this switch to sound the horn.

EAU12660

Engine stop switch “ O / X ”

Set this switch to “ O ” before starting the engine. Set this switch to “ X ” to stop the engine in case of an emergency, such as when the motorcycle overturns or when the throttle cable is stuck.

INSTRUMENT AND CONTROL FUNCTIONS

Start switch “○”

Push this switch to crank the engine with the starter.

EAU12710

ECA10050

CAUTION:

See page 5-1 for starting instructions prior to starting the engine.

3

Clutch lever

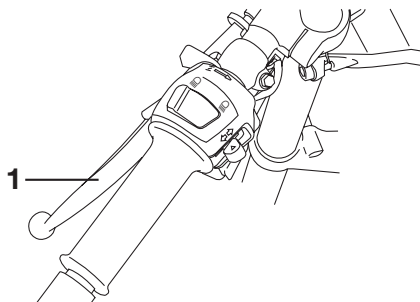

1. Clutch lever

The clutch lever is located at the left handlebar grip. To disengage the clutch, pull the lever toward the handlebar grip. To engage the clutch, release the lever. The lever should be pulled rapidly and released slowly for smooth clutch operation.

The clutch lever is equipped with a clutch switch, which is part of the starting circuit cut-off system. (See page 3-10.)

EAU31640

Shift pedal

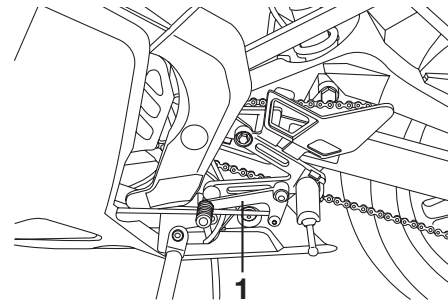

1. Shift pedal

The shift pedal is located on the left side of the engine and is used in combination with the clutch lever when shifting the gears of the 6-speed constant-mesh transmission equipped on this motorcycle.

EAU12870

INSTRUMENT AND CONTROL FUNCTIONS

EAU12890

Brake lever

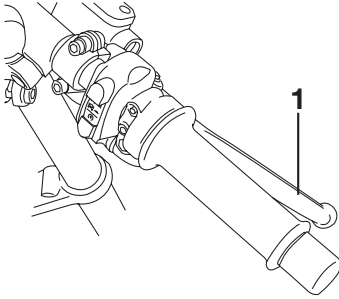

1. Brake lever

The brake lever is located at the right handlebar grip. To apply the front brake, pull the lever toward the handlebar grip.

EAU12941

Brake pedal

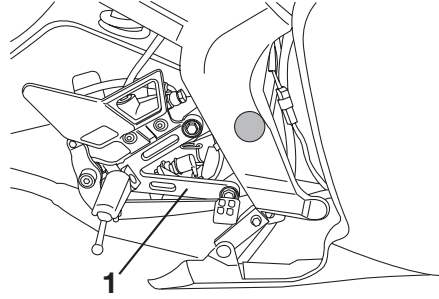

1. Brake pedal

The brake pedal is on the right side of the motorcycle. To apply the rear brake, press down on the brake pedal.

EAU13210

Fuel

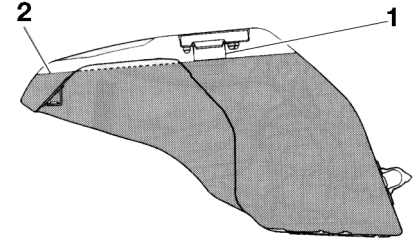

1. Fuel tank filler tube
2. Fuel level

Make sure that there is sufficient fuel in the tank. Fill the fuel tank to the bottom of the filler tube as shown.

⚠ WARNING

- Do not overfill the fuel tank, otherwise it may overflow when the fuel warms up and expands.
- Avoid spilling fuel on the hot engine.

EWA10880

INSTRUMENT AND CONTROL FUNCTIONS

ECA10070

CAUTION:

Immediately wipe off spilled fuel with a clean, dry, soft cloth, since fuel may deteriorate painted surfaces or plastic parts.

EAU13270

Recommended fuel:

REGULAR UNLEADED GASOLINE ONLY

Fuel tank capacity:

13.8 L (3.65 US gal) (3.04 Imp gal)

Fuel reserve amount:

2.2 L (0.58 US gal) (0.48 Imp gal)

Your Yamaha engine has been designed to use regular unleaded gasoline with a research octane number of 91 or higher. If knocking (or pinging) occurs, use a gasoline of a different brand or premium unleaded fuel. Use of unleaded fuel will extend spark plug life and reduce maintenance costs.

Catalytic converter

This model is equipped with a catalytic converter in the exhaust system.

EAU13431

WARNING

The exhaust system is hot after operation. Make sure that the exhaust system has cooled down before doing any maintenance work.

EWA10860

CAUTION:

The following precautions must be observed to prevent a fire hazard or other damages.

ECA10700

- Use only unleaded gasoline. The use of leaded gasoline will cause unreparable damage to the catalytic converter.
- Never park the vehicle near possible fire hazards such as grass or other materials that easily burn.
- Do not allow the engine to idle too long.

Fuel tank cap

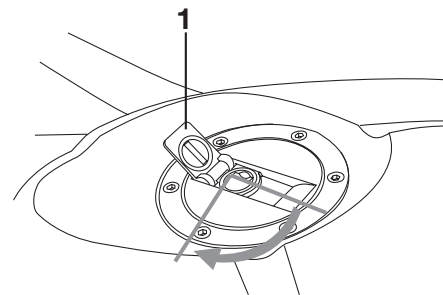

1. Fuel tank cap lock cover
2. Unlock

To open the fuel tank cap

Open the fuel tank cap lock cover, insert the key into the lock, and then turn it 1/4 turn clockwise. The lock will be released and the fuel tank cap can be opened.

To close the fuel tank cap

1. Push the fuel tank cap into position with the key inserted in the lock.
2. Turn the key counterclockwise to the original position, remove it, and then close the lock cover.

INSTRUMENT AND CONTROL FUNCTIONS

EAUB1300

EAU13460

NOTE:

The fuel tank cap cannot be closed unless the key is in the lock. In addition, the key cannot be removed if the cap is not properly closed and locked.

⚠ WARNING

Make sure that the fuel tank cap is properly closed before riding.

EWA11090

Fuel tank breather/overflow hose

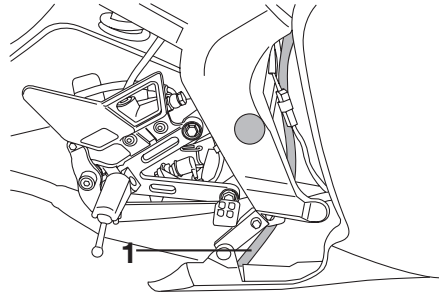

1. Fuel tank breather/overflow hose

Before operating the motorcycle:

- Check the fuel tank breather/overflow hose connection.
- Check the fuel tank breather/overflow hose for cracks or damage, and replace it if damaged.
- Make sure that the end of the fuel tank breather/overflow hose is not blocked, and clean it if necessary.
- Make sure that the end of the fuel tank breather/overflow hose is positioned inside of the clamp.

2-stroke engine oil

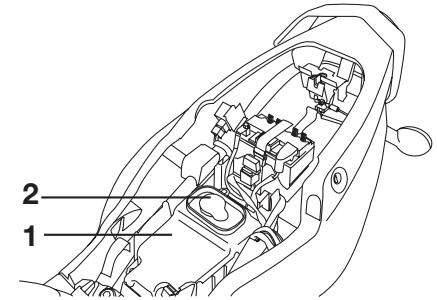

1. 2-stroke engine oil tank
2. 2-stroke engine oil tank cap

Make sure that there is sufficient oil in the 2-stroke engine oil tank. Add the recommended 2-stroke engine oil if necessary.

NOTE:

Make sure that the 2-stroke engine oil tank cap is properly installed.

Recommended oil:

Yamalube 2 or equivalent 2-stroke engine oil (JASO grade "FC", or ISO grades "EG-C" or "EG-D")

Oil quantity:

1.4 L (1.48 US qt) (1.23 Imp qt)

INSTRUMENT AND CONTROL FUNCTIONS

EAU13561

Fuel cock

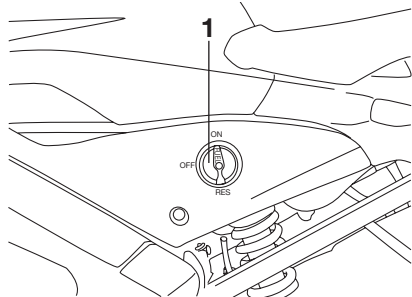

1. Fuel cock

The fuel cock supplies fuel from the tank to the carburetor while filtering it also.

The fuel cock has three positions:

OFF

With the lever in this position, fuel will not flow. Always return the lever to this position when the engine is not running.

ON

With the lever in this position, fuel flows to the carburetor. Normal riding is done with the lever in this position.

RES

This indicates reserve. If you run out of fuel while riding, move the lever to this position. Fill the tank at the first opportunity. Be sure to set the lever back to "ON" after refueling!

EAU13590

Starter (choke) lever "1"

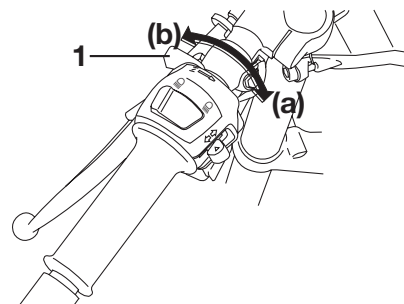

1. Starter (choke) lever

Starting a cold engine requires a richer air-fuel mixture, which is supplied by the starter (choke).

Move the lever in direction (a) to turn on the starter (choke).

Move the lever in direction (b) to turn off the starter (choke).

INSTRUMENT AND CONTROL FUNCTIONS

EAU13900

Seat

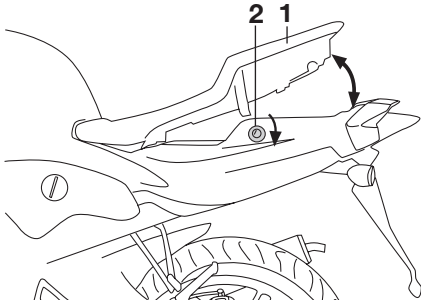

1. Seat
2. Seat lock

To remove the seat

1. Insert the key into the seat lock, and then turn it as shown.
2. Pull the seat off.

To install the seat

1. Insert the projection on the front of the seat into the seat holder as shown.
2. Push the rear of the seat down to lock it in place.
3. Remove the key.

NOTE:

Make sure that the seat is properly secured before riding.

EAU1940

Anti-theft device housing

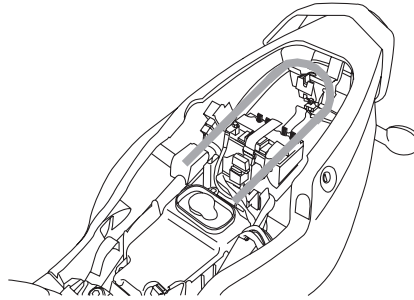

The anti-theft device housing, located in the storage compartment under the seat, is designed to hold a genuine Yamaha U-LOCK. (See page 3-9 for seat opening and closing procedures.) When placing a U-LOCK in the storage compartment, securely fasten it with the straps. When the U-LOCK is not in the storage compartment, be sure to secure the straps to prevent losing them.

NOTE:

Some U-LOCKS cannot fit into the housing due to their size or shape.

EAU39671

Rear view mirrors

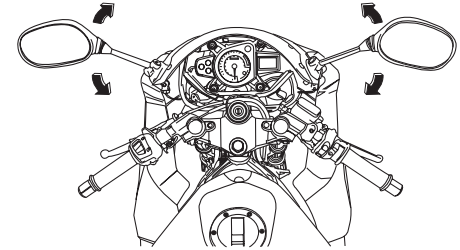

The rear view mirrors of this vehicle can be folded forward or backward for parking in narrow spaces. Fold the mirrors back to their original position before riding.

EWA14371

⚠ WARNING

Be sure to fold the rear view mirrors back to their original position before riding.

INSTRUMENT AND CONTROL FUNCTIONS

EAU15301

Sidestand

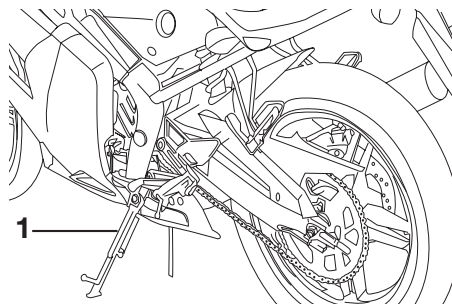

1. Sidestand

The sidestand is located on the left side of the frame. Raise the sidestand or lower it with your foot while holding the motorcycle upright.

NOTE:

The built-in sidestand switch is part of the ignition circuit cut-off system, which cuts the ignition in certain situations. (See further down for an explanation of the ignition circuit cut-off system.)

EWA10240

⚠ WARNING

The vehicle must not be ridden with the sidestand down, or if the sidestand cannot be properly moved up (or does not stay up), otherwise the sidestand could contact the ground and distract the operator, resulting in a possible loss of control. Yamaha's ignition circuit cut-off system has been designed to assist the operator in fulfilling the responsibility of raising the sidestand before starting off. Therefore, check this system regularly as described below and have a Yamaha dealer repair it if it does not function properly.

EAU15311

Ignition circuit cut-off system

The ignition circuit cut-off system (comprising the sidestand switch, clutch switch and neutral switch) has the following functions.

- It prevents starting when the transmission is in gear and the sidestand is up, but the clutch lever is not pulled.
- It prevents starting when the transmission is in gear and the clutch lever is pulled, but the sidestand is still down.
- It cuts the running engine when the transmission is in gear and the sidestand is moved down.

Periodically check the operation of the ignition circuit cut-off system according to the following procedure.

EWA10250

⚠ WARNING

If a malfunction is noted, have a Yamaha dealer check the system before riding.

INSTRUMENT AND CONTROL FUNCTIONS

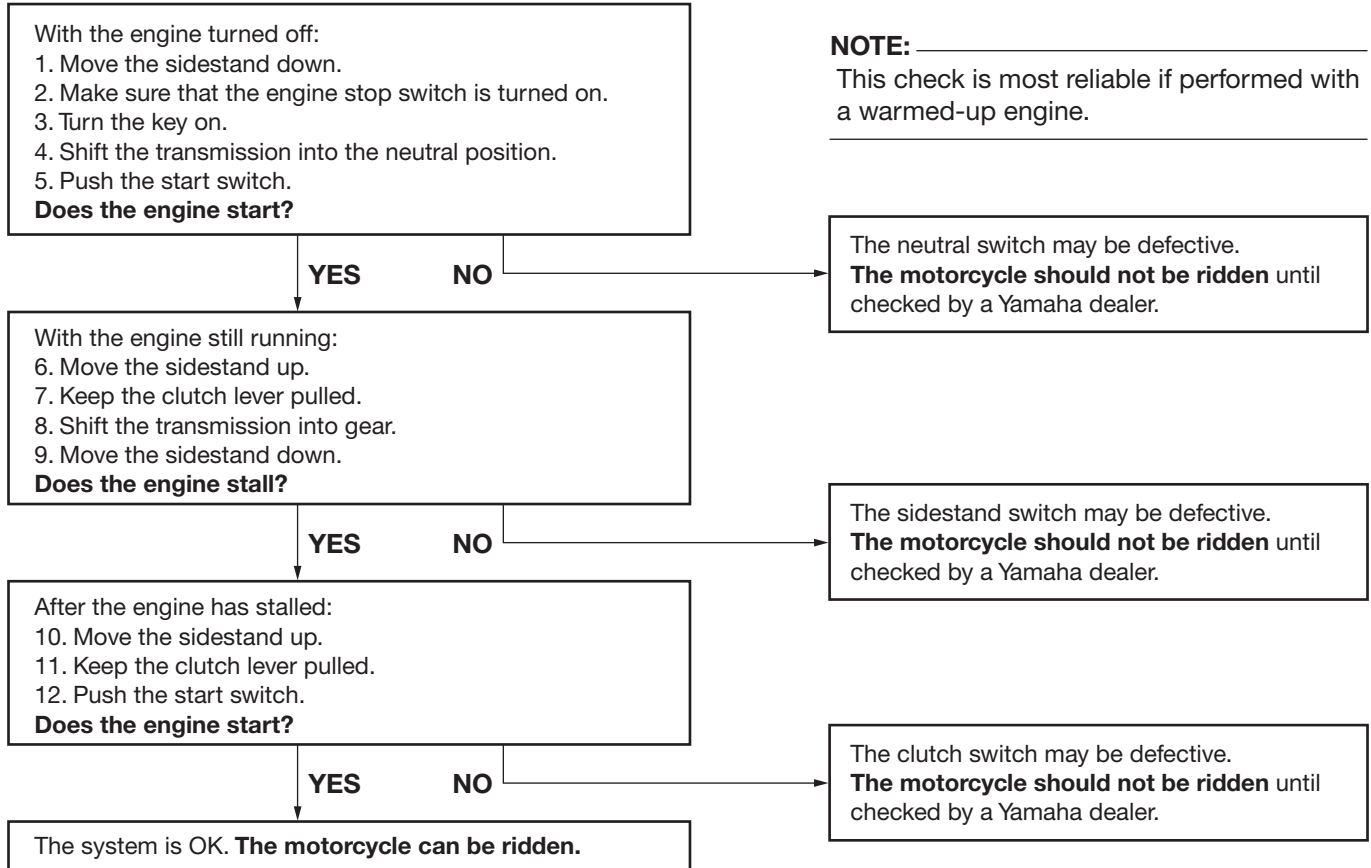

PRE-OPERATION CHECKS

EAU15591

The condition of a vehicle is the owner's responsibility. Vital components can start to deteriorate quickly and unexpectedly, even if the vehicle remains unused (for example, as a result of exposure to the elements). Any damage, fluid leakage or loss of tire air pressure could have serious consequences. Therefore, it is very important, in addition to a thorough visual inspection, to check the following points before each ride.

4

NOTE: _____

Pre-operation checks should be made each time the vehicle is used. Such an inspection can be accomplished in a very short time; and the added safety it assures is more than worth the time involved.

EWA11150

⚠ WARNING _____

If any item in the Pre-operation check list is not working properly, have it inspected and repaired before operating the vehicle.

PRE-OPERATION CHECKS

EAU15603

Pre-operation check list

ITEM	CHECKS	PAGE
Fuel	<ul style="list-style-type: none"> • Check fuel level in fuel tank. • Refuel if necessary. • Check fuel line for leakage. 	3-5, 3-6, 3-7
2-stroke engine oil	<ul style="list-style-type: none"> • Check oil level in oil tank. • If necessary, add recommended oil to specified level. • Check vehicle for oil leakage. 	3-7
Transmission oil	<ul style="list-style-type: none"> • Check oil level in transmission case. • If necessary, add recommended oil to specified level. 	6-8
Coolant	<ul style="list-style-type: none"> • Check coolant level in reservoir. • If necessary, add recommended coolant to specified level. • Check cooling system for leakage. 	6-9
Front brake	<ul style="list-style-type: none"> • Check operation. • If soft or spongy, have Yamaha dealer bleed hydraulic system. • Check brake pads for wear. • Replace if necessary. • Check fluid level in reservoir. • If necessary, add recommended brake fluid to specified level. • Check hydraulic system for leakage. 	3-5, 6-17 ~ 6-20
Rear brake	<ul style="list-style-type: none"> • Check operation. • If soft or spongy, have Yamaha dealer bleed hydraulic system. • Check brake pads for wear. • Replace if necessary. • Check fluid level in reservoir. • If necessary, add recommended brake fluid to specified level. • Check hydraulic system for leakage. 	3-5, 6-17 ~ 6-20
Clutch	<ul style="list-style-type: none"> • Check operation. • Lubricate cable if necessary. • Check lever free play. • Adjust if necessary. 	3-4, 6-16, 6-24
Throttle grip	<ul style="list-style-type: none"> • Make sure that operation is smooth. • Check cable free play. • If necessary, have Yamaha dealer adjust cable free play and lubricate cable and grip housing. 	6-12, 6-23

PRE-OPERATION CHECKS

ITEM	CHECKS	PAGE
Control cables	<ul style="list-style-type: none"> • Make sure that operation is smooth. • Lubricate if necessary. 	6-23
Drive chain	<ul style="list-style-type: none"> • Check chain slack. • Adjust if necessary. • Check chain condition. • Lubricate if necessary. 	6-21, 6-22
Wheels and tires	<ul style="list-style-type: none"> • Check for damage. • Check tire condition and tread depth. • Check air pressure. • Correct if necessary. 	6-14, 6-16
Brake and shift pedals	<ul style="list-style-type: none"> • Make sure that operation is smooth. • Lubricate pedal pivoting points if necessary. 	3-4, 3-5, 6-24
Brake and clutch levers	<ul style="list-style-type: none"> • Make sure that operation is smooth. • Lubricate lever pivoting points if necessary. 	3-4, 3-5, 6-24
Sidestand	<ul style="list-style-type: none"> • Make sure that operation is smooth. • Lubricate pivot if necessary. 	3-10, 6-25
Chassis fasteners	<ul style="list-style-type: none"> • Make sure that all nuts, bolts and screws are properly tightened. • Tighten if necessary. 	—
Instruments, lights, signals and switches	<ul style="list-style-type: none"> • Check operation. • Correct if necessary. 	—
Engine stop switch	<ul style="list-style-type: none"> • Check operation. 	3-3
Sidestand switch	<ul style="list-style-type: none"> • Check operation of ignition circuit cut-off system. • If system is defective, have Yamaha dealer check vehicle. 	3-10

OPERATION AND IMPORTANT RIDING POINTS

EAU15950
EWA10270

WARNING

- **Become thoroughly familiar with all operating controls and their functions before riding. Consult a Yamaha dealer regarding any control or function that you do not thoroughly understand.**
- **Never start the engine or operate it in a closed area for any length of time. Exhaust fumes are poisonous, and inhaling them can cause loss of consciousness and death within a short time. Always make sure that there is adequate ventilation.**
- **Before starting out, make sure that the sidestand is up. If the sidestand is not raised completely, it could contact the ground and distract the operator, resulting in a possible loss of control.**

EAU16050

Starting a cold engine

In order for the ignition circuit cut-off system to enable starting, one of the following conditions must be met:

- The transmission is in the neutral position.
- The transmission is in gear with the clutch lever pulled and the sidestand up.

EWA10290

WARNING

- **Before starting the engine, check the function of the ignition circuit cut-off system according to the procedure described on page 3-11.**
- **Never ride with the sidestand down.**

1. Turn the fuel cock lever to “ON”.
2. Turn the key to “○” and make sure that the engine stop switch is set to “○”.
3. Shift the transmission into the neutral position.

NOTE:

When the transmission is in the neutral position, the neutral indicator light

should be on, otherwise have a Yamaha dealer check the electrical circuit.

4. Turn the starter (choke) on and completely close the throttle. (See page 3-8.)
5. Start the engine by pushing the start switch.

NOTE:

If the engine fails to start, release the start switch, wait a few seconds, and then try again. Each starting attempt should be as short as possible to preserve the battery. Do not crank the engine more than 10 seconds on any one attempt.

ECA11410

CAUTION:

The 2-stroke engine oil level warning light should come on when the start switch is pushed, and it should go off when the start switch is released. If the warning light flickers or remains on after starting, immediately stop the engine, and then check the 2-stroke engine oil level and the vehicle for oil leakage.

OPERATION AND IMPORTANT RIDING POINTS

If necessary, add 2-stroke engine oil, and then check the warning light again. If the warning light does not come on when pushing the start switch, or if it does not go off after starting with sufficient 2-stroke engine oil, have a Yamaha dealer check the electrical circuit.

6. After starting the engine, move the starter (choke) back halfway.

ECA11040

5

CAUTION:

For maximum engine life, never accelerate hard when the engine is cold!

7. When the engine is warm, turn the starter (choke) off.

NOTE:

The engine is warm when it responds normally to the throttle with the starter (choke) turned off.

EAU16640

Starting a warm engine

Follow the same procedure as for starting a cold engine with the exception that the starter (choke) is not required when the engine is warm.

EAU16671

Shifting

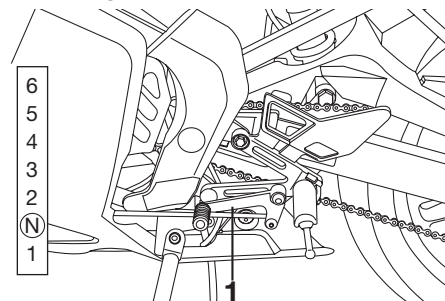

1. Shift pedal

Shifting gears lets you control the amount of engine power available for starting off, accelerating, climbing hills, etc.

The gear positions are shown in the illustration.

NOTE:

To shift the transmission into the neutral position, press the shift pedal down repeatedly until it reaches the end of its travel, and then slightly raise it.

OPERATION AND IMPORTANT RIDING POINTS

ECA10260

EAU16800

EAU16830

CAUTION:

- **Even with the transmission in the neutral position, do not coast for long periods of time with the engine off, and do not tow the motorcycle for long distances. The transmission is properly lubricated only when the engine is running. Inadequate lubrication may damage the transmission.**
- **Always use the clutch while changing gears to avoid damaging the engine, transmission, and drive train, which are not designed to withstand the shock of forced shifting.**

Tips for reducing fuel consumption

Fuel consumption depends largely on your riding style. Consider the following tips to reduce fuel consumption:

- Turn the starter (choke) off as soon as possible.
- Shift up swiftly, and avoid high engine speeds during acceleration.
- Do not rev the engine while shifting down, and avoid high engine speeds with no load on the engine.
- Turn the engine off instead of letting it idle for an extended length of time (e.g., in traffic jams, at traffic lights or at railroad crossings).

Engine break-in

There is never a more important period in the life of your engine than the period between 0 and 1000 km (600 mi). For this reason, you should read the following material carefully.

Since the engine is brand new, do not put an excessive load on it for the first 1000 km (600 mi). The various parts in the engine wear and polish themselves to the correct operating clearances. During this period, prolonged full-throttle operation or any condition that might result in engine overheating must be avoided.

EAU17130

0~500 km (0~300 mi)

Avoid prolonged operation above 4.000 r/min.

After every hour of operation, stop the engine, and then let it cool for five to ten minutes.

Vary the engine speed from time to time. Do not operate the engine at one set throttle position.

OPERATION AND IMPORTANT RIDING POINTS

500~1000 km (300~600 mi)

Avoid prolonged operation above 6.000 r/min.

Rev the engine freely through the gears, but do not use full throttle at any time.

ECA10370

CAUTION:

After 1000 km (600 mi) of operation, the transmission oil must be changed.

5

1000 km (600 mi) and beyond

The vehicle can now be operated normally.

ECA10310

CAUTION:

- Keep the engine speed out of the tachometer red zone.
- If any engine trouble should occur during the engine break-in period, immediately have a Yamaha dealer check the vehicle.

EAU17180

Parking

When parking, stop the engine, remove the key from the main switch, and then turn the fuel cock lever to “OFF”.

EWA10310

WARNING

- Since the engine and exhaust system can become very hot, park in a place where pedestrians or children are not likely to touch them.
- Do not park on a slope or on soft ground, otherwise the vehicle may overturn.

ECA10380

CAUTION:

Never park in an area where there are fire hazards such as grass or other flammable materials.

PERIODIC MAINTENANCE AND MINOR REPAIR

EAU17240

Safety is an obligation of the owner. Periodic inspection, adjustment and lubrication will keep your vehicle in the safest and most efficient condition possible. The most important points of inspection, adjustment, and lubrication are explained on the following pages.

The intervals given in the periodic maintenance and lubrication chart should be simply considered as a general guide under normal riding conditions. However, DEPENDING ON THE WEATHER, TERRAIN, GEOGRAPHICAL LOCATION, AND INDIVIDUAL USE, THE MAINTENANCE INTERVALS MAY NEED TO BE SHORTENED.

EWA10320

⚠ WARNING

If you are not familiar with maintenance work, have a Yamaha dealer do it for you.

EAU17520

Owner's tool kit

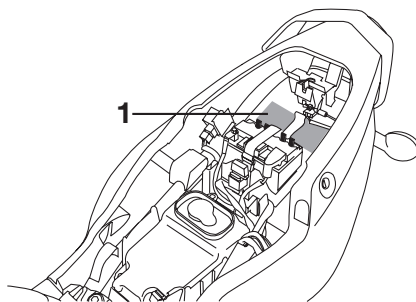

1. Owner's tool kit

The owner's tool kit is located inside the storage compartment under the seat. (See page 3-9.)

The service information included in this manual and the tools provided in the owner's tool kit are intended to assist you in the performance of preventive maintenance and minor repairs. However, additional tools such as a torque wrench may be necessary to perform certain maintenance work correctly.

NOTE:

If you do not have the tools or experience required for a particular job, have a Yamaha dealer perform it for you.

EWA10350

⚠ WARNING

Modifications not approved by Yamaha may cause loss of performance and render the vehicle unsafe for use. Consult a Yamaha dealer before attempting any changes.

PERIODIC MAINTENANCE AND MINOR REPAIR

EAU17710

Periodic maintenance and lubrication chart

NOTE:

- The annual checks must be performed every year, except if a kilometer-based maintenance is performed instead.
- From 30000 km, repeat the maintenance intervals starting from 6000 km.
- Items marked with an asterisk should be performed by a Yamaha dealer as they require special tools, data and technical skills.

NO	ITEM	CHECK OR MAINTENANCE JOB	ODOMETER READING (x 1000 Km)					ANNUAL CHECK
			1	6	12	18	24	
1	* Fuel line	• Check fuel hoses for cracks or damage.		√	√	√	√	√
2	Spark plug	• Replace.		√	√	√	√	√
3	* Air filter element	• Clean.		√		√		
		• Replace.			√		√	
4	Clutch	• Check operation. • Adjust.	√	√	√	√	√	
5	* Front brake	• Check operation, fluid level and vehicle for fluid leakage.	√	√	√	√	√	√
		• Replace brake pads.	Whenever worn to the limit					
6	* Rear brake	• Check operation, fluid level and vehicle for fluid leakage.	√	√	√	√	√	√
		• Replace brake pads.	Whenever worn to the limit					
7	* Brake hose	• Check for cracks or damage.		√		√	√	√
		• Replace.	Every 4 years					
8	* Wheels	• Check runout and for damage.		√	√	√	√	

6

PERIODIC MAINTENANCE AND MINOR REPAIR

NO	ITEM	CHECK OR MAINTENANCE JOB	ODOMETER READING (x 1000 Km)					ANNUAL CHECK
			1	6	12	18	24	
9 *	Tires	<ul style="list-style-type: none"> • Check tread depth and for damage. • Replace if necessary. • Check air pressure. • Correct if necessary. 		√	√	√	√	√
10 *	Wheel bearings	<ul style="list-style-type: none"> • Check bearing for looseness or damage. 		√	√	√	√	
11 *	Swingarm	<ul style="list-style-type: none"> • Check operation and for excessive play. • Lubricate with lithium-soap-based grease. 	Every 24000 km					
12	Drive chain	<ul style="list-style-type: none"> • Check chain slack, alignment and condition. • Adjust and lubricate chain with a special O-ring chain lubricant thoroughly. 	Every 500 km and after washing the motorcycle or riding in the rain					
13 *	Steering bearings	<ul style="list-style-type: none"> • Check bearing play and steering for roughness. • Lubricate with lithium-soap-based grease. 	√	√	√	√	√	
14 *	Chassis fasteners	<ul style="list-style-type: none"> • Make sure that all nuts, bolts and screws are properly tightened. 		√	√	√	√	√
15	Sidestand	<ul style="list-style-type: none"> • Check operation. • Lubricate. 		√	√	√	√	√
16 *	Sidestand switch	<ul style="list-style-type: none"> • Check operation. 	√	√	√	√	√	√
17 *	Front fork	<ul style="list-style-type: none"> • Check operation and for oil leakage. 		√	√	√	√	
18 *	Rear suspension relay arm and connecting arm pivoting points	<ul style="list-style-type: none"> • Check operation. • Lubricate with lithium-soap-based grease. 		√	√	√	√	
19 *	Carburetor	<ul style="list-style-type: none"> • Check starter (choke) operation. • Adjust engine idling speed. 	√	√	√	√	√	√
20 *	Autolube pump	<ul style="list-style-type: none"> • Check operation. • Bleed if necessary. 	√		√		√	√

PERIODIC MAINTENANCE AND MINOR REPAIR

NO	ITEM	CHECK OR MAINTENANCE JOB	ODOMETER READING (x 1000 Km)					ANNUAL CHECK
			1	6	12	18	24	
21	Transmission oil	• Check oil level.	√	√	√	√	√	√
		• Change.	√				√	
22	* Front and rear brake switches	• Check operation.	√	√	√	√	√	√
23	Moving parts and cables	• Lubricate.		√	√	√	√	√
24	* Throttle grip housing and cable	• Check operation and free play. • Adjust the throttle cable free play if necessary. • Lubricate the throttle grip housing and cable.		√	√	√	√	√
25	* Lights, signals and switches	• Check operation. • Adjust headlight beam.	√	√	√	√	√	√

NOTE:

- Replace the air filter element more frequently if you are riding in unusually wet or dusty areas.
- Hydraulic brake service
 - Regularly check and, if necessary, correct the brake fluid level.
 - Every two years replace the internal components of the brake master cylinder, and change the brake fluid.
 - Replace the brake hoses every four years and if cracked or damaged.

PERIODIC MAINTENANCE AND MINOR REPAIR

Removing and installing cowlings and panels

The cowlings and panels shown need to be removed to perform some of the maintenance jobs described in this chapter. Refer to this section each time a cowling or panel needs to be removed and installed.

EAU18712

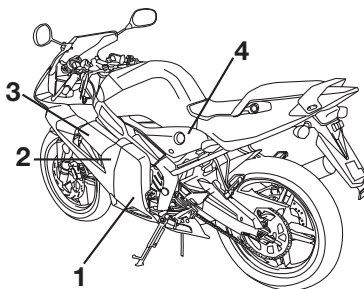

1. Cowling A (screws x 5)
2. Cowling B (screws x 7)
3. Cowling C (screw x 1)
4. Panel B (screw x 1)

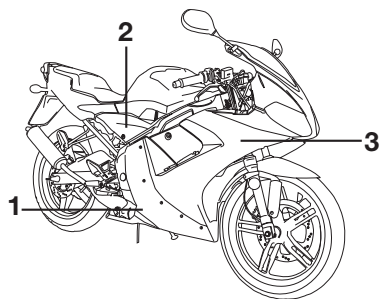

1. Cowling A (screws x 7)
2. Panel A (screw x 1)
3. Cowling B (screws x 5)

Cowling A

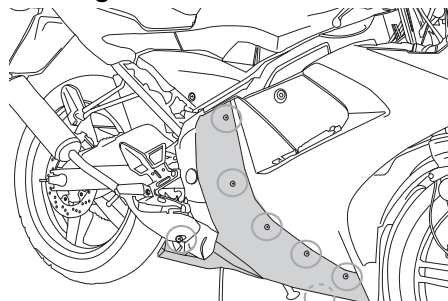

EAU18790

To remove the cowling

Remove the screws, and then take the cowling off.

To install the cowling

Place the cowling in the original position, and then install the screws.

Cowling B

EAU18951

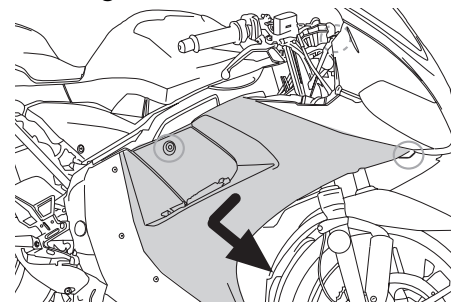

To remove the cowling

1. Remove cowling A.
2. Remove the screws, and then pull the cowling off as shown.

To install the cowling

1. Place the cowling in the original position, and then install the screws.

NOTE:

Make sure that the projection fits into the grommet.

2. Install cowling A.

PERIODIC MAINTENANCE AND MINOR REPAIR

EAU18810

Cowling C

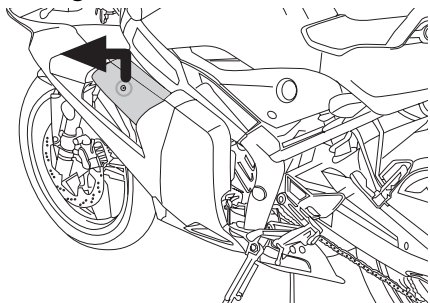

To remove the cowling

Remove the screw, and then pull the cowling off as shown.

To install the cowling

Place the cowling in the original position, and then install the screw.

EAU19272

Panel A

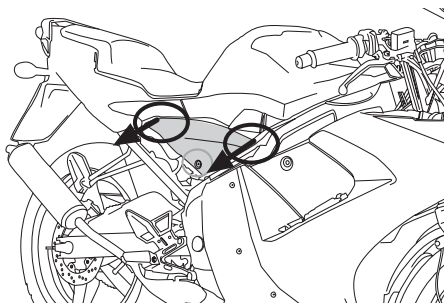

To remove the panel

Remove the screw, and then pull outward on the areas shown.

To install the panel

Place the panel in the original position, and then install the screw.

EAU19280

Panel B

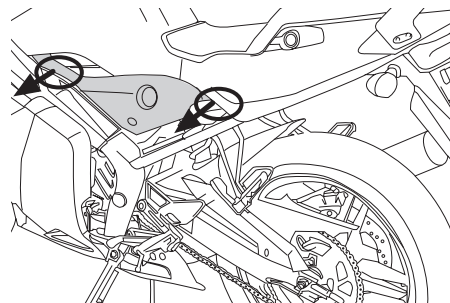

To remove the panel

Remove the screw, and then pull the panel off as shown.

To install the panel

Place the panel in the original position, and then install the screw.

PERIODIC MAINTENANCE AND MINOR REPAIR

EAU19630

Checking the spark plug

The spark plug is an important engine component, which is easy to check. Since heat and deposits will cause any spark plug to slowly erode, the spark plug should be removed and checked in accordance with the periodic maintenance and lubrication chart. In addition, the condition of the spark plug can reveal the condition of the engine.

To remove the spark plug

1. Remove cowling C. (See page 6-5.)

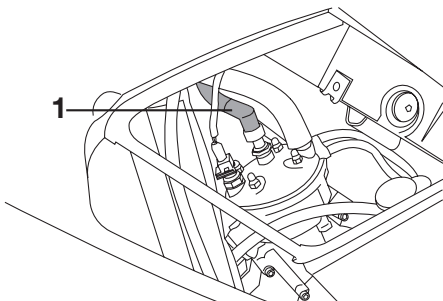

1. Spark plug cap

2. Remove the spark plug cap.

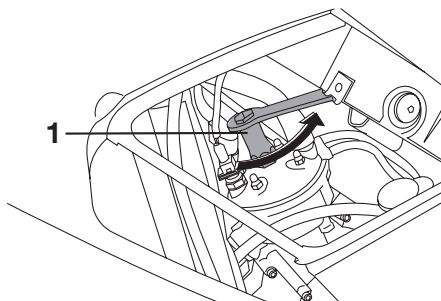

1. Spark plug wrench

3. Remove the spark plug as shown, with the spark plug wrench included in the owner's tool kit.

To check the spark plug

1. Check that the porcelain insulator around the center electrode of the spark plug is a medium-to-light tan (the ideal color when the motorcycle is ridden normally).

NOTE:

If the spark plug shows a distinctly different color, the engine could be defective. Do not attempt to diagnose such problems yourself. Instead, have a Yamaha dealer check the motorcycle.

2. Check the spark plug for electrode erosion and excessive carbon or other deposits, and replace it if necessary.

Specified spark plug:
NGK BR9 ES

To install the spark plug

1. Measure the spark plug gap with a wire thickness gauge and, if necessary, adjust the gap to specification.

Spark plug gap:
0.6 ~ 0.7 mm (0.023 ~ 0.027 in)

2. Clean the surface of the spark plug gasket and its mating surface, and then wipe off any grime from the spark plug threads.

PERIODIC MAINTENANCE AND MINOR REPAIR

EAUM1270

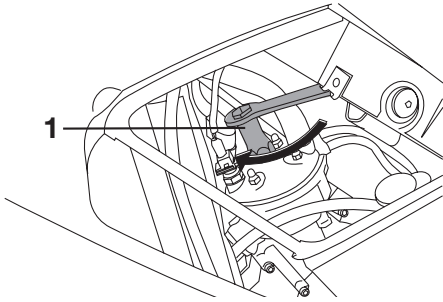

1. Spark plug wrench

3. Install the spark plug with the spark plug wrench, and then tighten it to the specified torque.

Tightening torque:

Spark plug:

22.5 Nm (2.2 m•kgf, 16.3 ft•lbf)

NOTE:

If a torque wrench is not available when installing a spark plug, a good estimate of the correct torque is 1/4~1/2 turn past finger tight. However, the spark plug should be tightened to the specified torque as soon as possible.

4. Install the spark plug cap.
5. Install the cowling.

Transmission oil

The transmission oil level should be checked before each ride. In addition, the oil must be changed at the intervals specified in the periodic maintenance and lubrication chart.

To check the transmission oil level

1. Place the vehicle on a level surface and hold it in an upright position.

NOTE:

Make sure that the vehicle is positioned straight up when checking the oil level. A slight tilt to the side can result in a false reading.

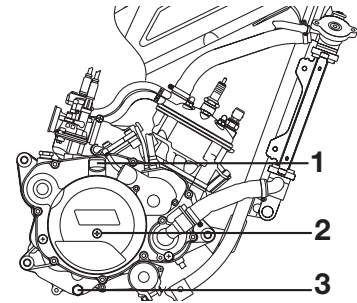

1. Oil filler cap
2. Oil check bolt
3. Transmission oil drain bolt

PERIODIC MAINTENANCE AND MINOR REPAIR

2. Remove the oil check bolt, and then check the oil level.

NOTE: _____

The oil should be at the brim of the check hole.

3. If the oil is below the brim of the check hole, remove the oil filler cap, add sufficient oil of the recommended type to raise it to the correct level, and then install the oil filler cap.
4. Install the oil check bolt, and then tighten it to the specified torque.

Tightening torque:

Oil check bolt:
6 Nm (0.6 m•kgf, 4.3 ft•lbf)

Tightening torque:

Transmission oil drain bolt:
17.5 Nm (1.7 m•kgf, 12.7 ft•lbf)
Oil check bolt:
6 Nm (0.6 m•kgf, 4.3 ft•lbf)

4. Remove the oil filler cap, add the specified amount of the recommended transmission oil, and then install and tighten the oil filler cap.

Recommended transmission oil:

See page 8-1.

Oil change quantity:

0.82 L (0.87 US qt) (0.72 Imp.qt)

ECAM1020

CAUTION: _____

Make sure that no foreign material enters the transmission case.

To change the transmission oil

1. Place an oil pan under the transmission oil case to collect the used oil.
2. Remove the drain bolt and the oil check bolt to drain the oil.
3. Install the drain bolt and the check bolt, and then tighten them to the specified torque.

5. Start the engine and let it idle for several minutes while checking the transmission oil case for oil leakage. If oil is leaking, immediately turn the engine off and check for the cause.

EAU20070

Coolant

The coolant level should be checked before each ride. In addition, the coolant must be changed at the intervals specified in the periodic maintenance and lubrication chart.

EAU33030

Changing the coolant

EWA10380

⚠ WARNING

Never attempt to remove the radiator cap when the engine is hot.

The coolant must be changed at the intervals specified in the periodic maintenance and lubrication chart. Have a Yamaha dealer change the coolant.

EAU20080

To check the coolant level

1. Place the vehicle on a level surface and hold it in an upright position.

PERIODIC MAINTENANCE AND MINOR REPAIR

NOTE:

- The coolant level must be checked on a cold engine since the level varies with engine temperature.
- Make sure that the vehicle is positioned straight up when checking the coolant level. A slight tilt to the side can result in a false reading.

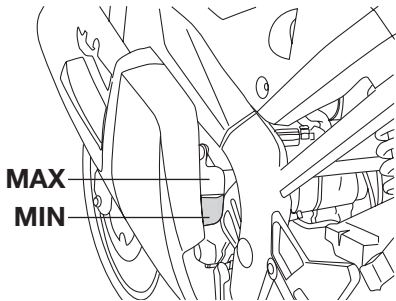

2. Check the coolant level in the coolant reservoir.

NOTE:

The coolant should be between the minimum and maximum level marks.

3. If the coolant is at or below the minimum level mark, open the

reservoir cap, add coolant to the maximum level mark, and then close the reservoir cap.

EWA10380

WARNING

Never attempt to remove the radiator cap when the engine is hot.

NOTE:

If the engine overheats, see page 6-33 for further instructions.

EAU20431

To change the coolant

1. Place the vehicle on the centerstand and let the engine cool if necessary.
2. Remove cowlings A and B. (See page 6-5.)
3. Place a container under the engine to collect the used coolant.

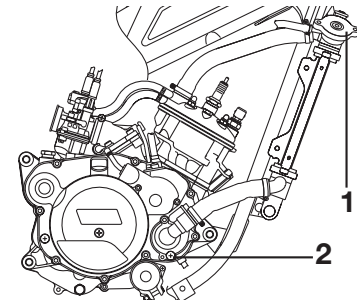

1. Radiator cap
2. Coolant drain bolt

4. Remove the radiator cap.

EWA10380

WARNING

Never attempt to remove the radiator cap when the engine is hot.

5. Remove the coolant drain bolt to drain the cooling system.
6. After the coolant is completely drained, thoroughly flush the cooling system with clean tap water.
7. Install the coolant drain bolt, and then tighten it to the specified torque.

PERIODIC MAINTENANCE AND MINOR REPAIR

NOTE:

Check the washer for damage and replace it if necessary.

Tightening torque:

Coolant drain bolt:
9 Nm (0.9 m•kgf, 6.5 ft•lbf)

8. Pour the recommended coolant into the radiator until it is full.

Recommended antifreeze:

High-quality ethylene glycol antifreeze containing corrosion inhibitors for aluminum engines

Antifreeze/water mixture ratio:

1:1

Coolant quantity:

Radiator capacity (including all routes):

0.70 L (0.74 US qt) (0.62 Imp qt)

Coolant reservoir capacity:

0.29L (0.31 US qt) (0.26 Imp qt)

ECA10470

CAUTION:

- **If coolant is not available, use distilled water or soft tap water instead. Do not use hard water or salt water since it is harmful to the engine.**

- **If water has been used instead of coolant, replace it with coolant as soon as possible, otherwise the engine may not be sufficiently cooled and the cooling system will not be protected against frost and corrosion.**
- **If water has been added to the coolant, have a Yamaha dealer check the antifreeze content of the coolant as soon as possible, otherwise the effectiveness of the coolant will be reduced.**

12. Start the engine, and then check the vehicle for coolant leakage. If coolant is leaking, have a Yamaha dealer check the cooling system.
 13. Install the cowlings.
-
9. Install the radiator cap, start the engine, let it idle for several minutes, and then turn it off.
 10. Remove the radiator cap to check the coolant level in the radiator. If necessary, add sufficient coolant until it reaches the top of the radiator, and then install the radiator cap.
 11. Check the coolant level in the reservoir. If necessary, remove the coolant reservoir cap, add coolant to the maximum level mark, and then install the cap.

PERIODIC MAINTENANCE AND MINOR REPAIR

EAU40370

Air filter element

The air filter element must be cleaned and replaced at the intervals specified in the periodic maintenance and lubrication chart. Have a Yamaha dealer clean and replace the air filter element.

EAU21280

Adjusting the carburetor

The carburetor is an important part of the engine and requires very sophisticated adjustment. Therefore, most carburetor adjustments should be left to a Yamaha dealer, who has the necessary professional knowledge and experience. The adjustment described in the following section, however, may be serviced by the owner as part of routine maintenance.

ECA10550

CAUTION:

The carburetor has been set and extensively tested at the Yamaha factory. Changing these settings without sufficient technical knowledge may result in poor performance of or damage to the engine.

EAU21370

Adjusting the throttle cable free play

The throttle cable free play should measure 4 ~ 6 mm (0.15 ~ 0.23 in) at the throttle grip. Periodically check the throttle cable free play and, if necessary, adjust it as follows.

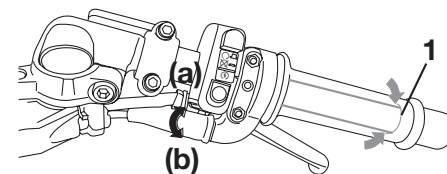

1. Throttle cable free play

NOTE:

The engine idling speed must be correctly adjusted before checking and adjusting the throttle cable free play.

1. To increase the throttle cable free play, turn the adjusting nut in direction (a). To decrease the

PERIODIC MAINTENANCE AND MINOR REPAIR

throttle cable free play, turn the adjusting nut in direction (b).

EAU33481

Adjusting the engine idling speed

The engine idling speed must be checked and, if necessary, adjusted as follows at the intervals specified in the periodic maintenance and lubrication chart.

The engine should be warm before making this adjustment.

NOTE: _____

The engine is warm when it quickly responds to the throttle.

1. Remove panel B. (See page 6-5.)

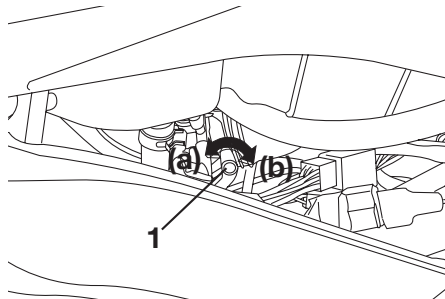

1. Idle adjusting screw

2. Check the engine idling speed and, if necessary, adjust it to specification by turning the idle adjusting screw. To increase the engine idling speed, turn the screw in direction (a). To decrease the engine idling speed, turn the screw in direction (b).

Engine idling speed:

1.600 ~ 1.900 r/min

NOTE: _____

If the specified idling speed cannot be obtained as described above, have a Yamaha dealer make the adjustment.

3. Install the panel.

PERIODIC MAINTENANCE AND MINOR REPAIR

EAU21560

Tires

To maximize the performance, durability, and safe operation of your motorcycle, note the following points regarding the specified tires.

Tire air pressure

The tire air pressure should be checked and, if necessary, adjusted before each ride.

EWA10500

WARNING

- The tire air pressure must be checked and adjusted on cold tires (i.e., when the temperature of the tires equals the ambient temperature).
- The tire air pressure must be adjusted in accordance with the riding speed and with the total weight of rider, passenger, cargo, and accessories approved for this model.

Tire air pressure (measured on cold tires):

Up to 90 kg (198 lb):

Front:

180 kPa (25 psi) (1.8 kgf/cm²)

Rear:

200 kPa (28 psi) (2.0 kgf/cm²)

90 kg (198 lb) to maximum load:

Front:

190 kPa (27 psi) (1.9 kgf/cm²)

Rear:

230 kPa (33 psi) (2.3 kgf/cm²)

Maximum load*:

196 kg (432.18 lb)

* Total weight of rider, passenger, cargo and accessories

EWA11020

WARNING

Because loading has an enormous impact on the handling, braking, performance and safety characteristics of your motorcycle, you should keep the following precautions in mind.

- **NEVER OVERLOAD THE MOTORCYCLE!** Operation of an overloaded motorcycle may result in tire damage, loss of

control, or severe injury. Make sure that the total weight of rider, passenger, cargo, and accessories does not exceed the specified maximum load for the vehicle.

- Do not carry along loosely packed items, which can shift during a ride.
- Securely pack the heaviest items close to the center of the motorcycle and distribute the weight evenly on both sides.
- Adjust the suspension and tire air pressure with regard to the load.
- Check the tire condition and air pressure before each ride.

PERIODIC MAINTENANCE AND MINOR REPAIR

EWA10470

Tire inspection

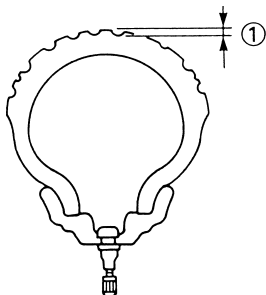

1. Tire tread depth

The tires must be checked before each ride. If the center tread depth reaches the specified limit, if the tire has a nail or glass fragments in it, or if the sidewall is cracked, have a Yamaha dealer replace the tire immediately.

Minimum tire tread depth (front and rear):

1.6 mm (0.06 in)

NOTE:

The tire tread depth limits may differ from country to country. Always comply with the local regulations.

Tire information

This motorcycle is equipped with cast wheels and tubeless tires.

EWA10460

WARNING

- The front and rear tires should be of the same make and design, otherwise the handling characteristics of the vehicle cannot be guaranteed.
- After extensive tests, only the tires listed below have been approved for this model by Yamaha Motor España, S.A.

Front tire:

Size:

100/80-17 MC 52 H

Manufacturer/model:

Pirelli / SPORT DEMON

Continental/Conti-Twist SM

Rear tire:

Size:

130/70-17 M/C 62 H

Manufacturer/model:

Pirelli / SPORT DEMON

Continental/Conti-Twist SM

WARNING

- Have a Yamaha dealer replace excessively worn tires. Besides being illegal, operating the vehicle with excessively worn tires decreases riding stability and can lead to loss of control.
- The replacement of all wheel and brake related parts, including the tires, should be left to a Yamaha dealer, who has the necessary professional knowledge and experience.

PERIODIC MAINTENANCE AND MINOR REPAIR

EAU21960

EAU22041

Cast wheels

To maximize the performance, durability, and safe operation of your motorcycle, note the following points regarding the specified wheels.

- The wheel rims should be checked for cracks, bends or warpage before each ride. If any damage is found, have a Yamaha dealer replace the wheel. Do not attempt even the smallest repair to the wheel. A deformed or cracked wheel must be replaced.
- The wheel should be balanced whenever either the tire or wheel has been changed or replaced. An unbalanced wheel can result in poor performance, adverse handling characteristics, and a shortened tire life.
- Ride at moderate speeds after changing a tire since the tire surface must first be “broken in” for it to develop its optimal characteristics.

Adjusting the clutch lever free play

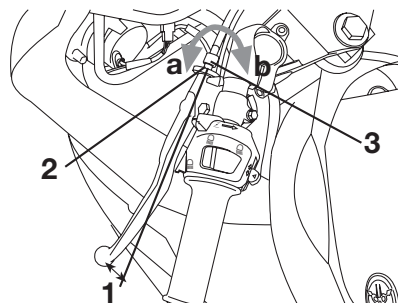

1. Clutch lever free play
2. Locknut (clutch lever)
3. Clutch lever free play adjusting bolt

The clutch lever free play should measure 10~15 mm (0.39~0.59 in) as shown. Periodically check the clutch lever free play and, if necessary, adjust it as follows.

1. Loosen the locknut at the clutch lever.
2. To increase the clutch lever free play, turn the adjusting bolt in direction (a). To decrease the clutch lever free play, turn the adjusting bolt in direction (b).

NOTE:

If the specified clutch lever free play could be obtained as described above, tighten the locknut and skip the rest of the procedure, otherwise proceed as follows.

3. Fully turn the adjusting bolt at the clutch lever in direction (a) to loosen the clutch cable.

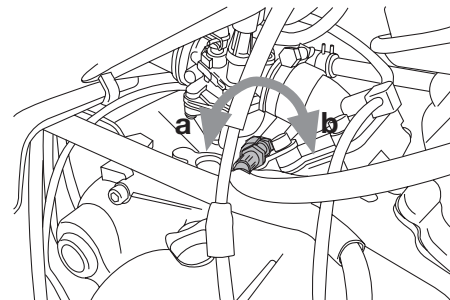

4. Loosen the locknut at the crankcase.
5. To increase the clutch lever free play, turn the adjusting nut in direction (a). To decrease the clutch lever free play, turn the adjusting nut in direction (b).
6. Tighten the locknut at the clutch lever and the crankcase.

PERIODIC MAINTENANCE AND MINOR REPAIR

EAUT1220

Checking the front brake lever free play

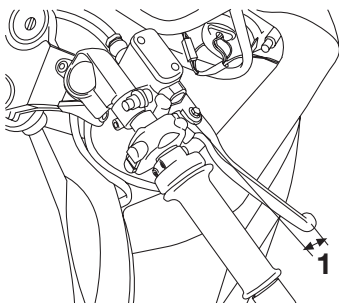

1. Brake lever free play

The brake lever free play should measure 2~5 mm (0.08~0.20 in) as shown. Periodically check the brake lever free play and, if necessary, have a Yamaha dealer check the brake system.

EWA10640

⚠ WARNING

An incorrect brake lever free play indicates a hazardous condition in the brake system. Do not operate the motorcycle until the brake system has been checked or repaired by a Yamaha dealer.

EAUM1352

Adjusting the brake pedal free play

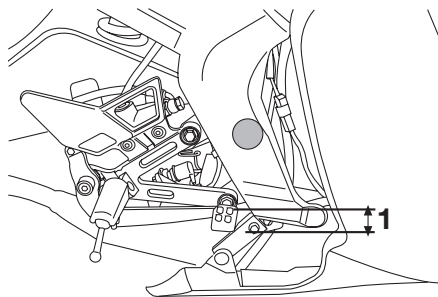

1. Brake pedal free play

The brake pedal free play should measure 10~15 mm (0.39~0.59 in) as shown. Periodically check the brake pedal free play and, if necessary, have a Yamaha dealer adjust it.

EWAM1010

⚠ WARNING

You are hereby informed that any attempt to change the engine or any other part to increase the scooter's performance or power is strictly forbidden by law.

- Any change resulting in an increase of the vehicle's maximum speed or in an increase of the engine's capacity entails a category classification shift from scooter to light motorcycle, with all the consequences relating to the latter category, compelling the owner to:
 - - proceed with a new certification,
 - - have the vehicle registered,
 - - hold a driving license (pursuant to the new legislation).

In addition, you are informed that such changes will bar you from insurance coverage insofar as insurance policies expressly stipulate that such technical changes brought with a view to enhancing performance are forbidden.

For the above-mentioned reasons, any violation of the rules forbidding personal or otherwise third-party interventions is punishable by law with penalties (including seizure of the vehicle) to which, as the case may be, penalties may be added relating to the failure to wear a

PERIODIC MAINTENANCE AND MINOR REPAIR

crash helmet, the failure to identify the vehicle, the failure to have an insurance, or the failure to hold a driving license.

Adjusting the shift pedal position

EAUB1100

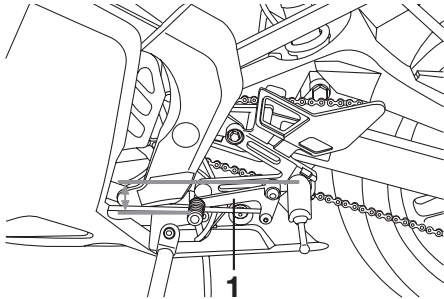

1. Shift pedal

The top of the shift pedal should be positioned approximately 65 mm (2.5590 in) below the top of the footrest as shown. Periodically check the shift pedal position and, if necessary, have a Yamaha dealer adjust it.

Adjusting the rear brake light switch

EAU22270

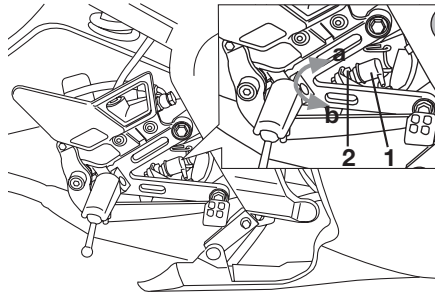

1. Rear brake light switch
2. Rear brake light switch adjusting nut

The rear brake light switch, which is activated by the brake pedal, is properly adjusted when the brake light comes on just before braking takes effect. If necessary, adjust the brake light switch as follows.

Turn the adjusting nut while holding the rear brake light switch in place. To make the brake light come on earlier, turn the adjusting nut in direction (a). To make the brake light come on later, turn the adjusting nut in direction (b).

Checking the front and rear brake pads

EAU22390

The front and rear brake pads must be checked for wear at the intervals specified in the periodic maintenance and lubrication chart.

Front brake pads

EAU22430

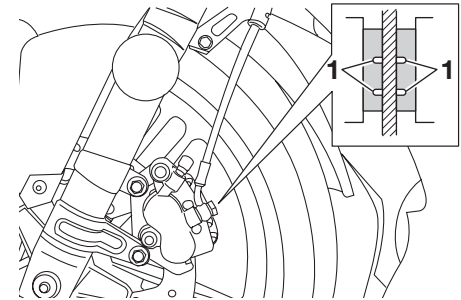

1. Brake pad wear indicator groove

Each front brake pad is provided with wear indicator grooves, which allow you to check the brake pad wear without having to disassemble the brake. To check the brake pad wear, check the wear indicator grooves. If a brake pad has worn to the point that the wear indicator grooves have almost

PERIODIC MAINTENANCE AND MINOR REPAIR

EAU22580

disappeared, have a Yamaha dealer replace the brake pads as a set.

2. Install the brake caliper bolt, and then tighten it to the specified torque.

Rear brake pads

EAU22480

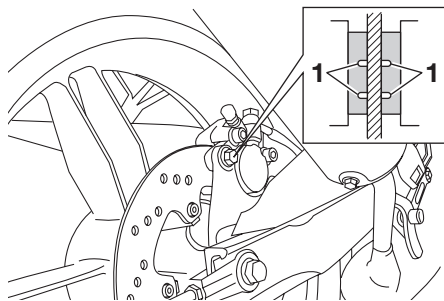

1. Brake pad wear indicator groove

Each rear brake pad is provided with a wear indicator groove, which allows you to check the brake pad wear without having to disassemble the brake. Check the brake pad wear as follows.

1. Remove the brake caliper bolt, and then tilt the caliper forward to inspect the wear indicator groove. If a brake pad has worn to the point that the wear indicator groove has almost disappeared, have a Yamaha dealer replace the brake pads as a set.

Tightening torque:
Brake caliper bolt:
30 Nm (3.0 m.kgf, 21.7 ft.lbf)

Checking the brake fluid level Front

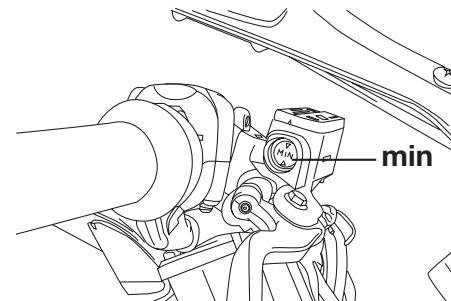

Rear

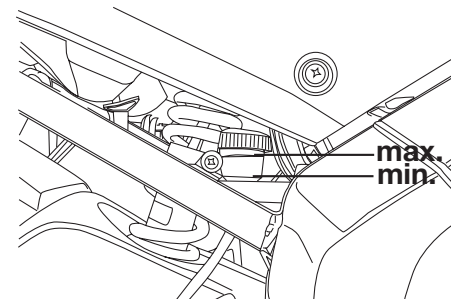

Insufficient brake fluid may allow air to enter the brake system, possibly causing it to become ineffective. Before riding, check that the brake

PERIODIC MAINTENANCE AND MINOR REPAIR

EAU22730

fluid is above the minimum level mark and replenish if necessary. A low brake fluid level may indicate worn brake pads and/or brake system leakage. If the brake fluid level is low, be sure to check the brake pads for wear and the brake system for leakage.

Observe these precautions:

- When checking the fluid level, make sure that the top of the brake fluid reservoir is level.
- Use only the recommended quality brake fluid, otherwise the rubber seals may deteriorate, causing leakage and poor braking performance.

Recommended brake fluid:
DOT 4

- Refill with the same type of brake fluid. Mixing fluids may result in a harmful chemical reaction and lead to poor braking performance.
- Be careful that water does not enter the brake fluid reservoir when refilling. Water will signifi-

cantly lower the boiling point of the fluid and may result in vapor lock.

- Brake fluid may deteriorate painted surfaces or plastic parts. Always clean up spilled fluid immediately.
- As the brake pads wear, it is normal for the brake fluid level to gradually go down. However, if the brake fluid level goes down suddenly, have a Yamaha dealer check the cause.

Changing the brake fluid

Have a Yamaha dealer change the brake fluid at the intervals specified in the NOTE after the periodic maintenance and lubrication chart. In addition, have the oil seals of the master cylinders and calipers as well as the brake hoses replaced at the intervals listed below or whenever they are damaged or leaking.

- Oil seals: Replace every two years.
- Brake hoses: Replace every four years.

PERIODIC MAINTENANCE AND MINOR REPAIR

EAU22760

Drive chain slack

The drive chain slack should be checked before each ride and adjusted if necessary.

EAU22781

To check the drive chain slack

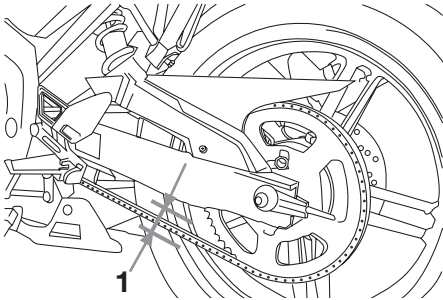

1. Drive chain slack

1. Place the motorcycle on the sidestand.

NOTE:

When checking and adjusting the drive chain slack, there should be no weight on the motorcycle.

2. Shift the transmission into the neutral position.

3. Move the rear wheel by pushing the motorcycle to locate the tightest portion of the drive chain, and then measure the drive chain slack as shown.

Drive chain slack:

20 ~ 25 mm (0.787 ~ 0.984 in)

4. If the drive chain slack is incorrect, adjust it as follows.

NOTE:

When checking the drive chain slack, the chain tensioner should not be touching the drive chain.

EAU22920

To adjust the drive chain slack

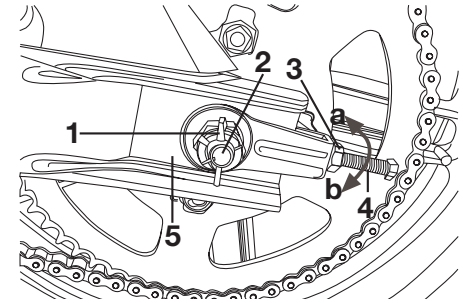

1. Cotter pin
2. Axle nut
3. Locknut
4. Drive chain slack adjusting bolt
5. Alignment marks

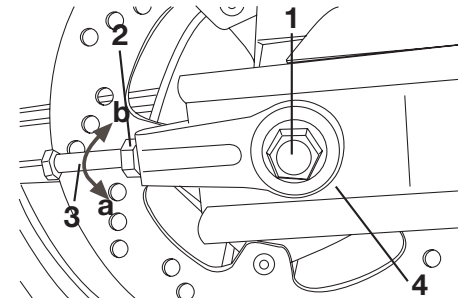

1. Axle nut
2. Locknut
3. Drive chain slack adjusting bolt
4. Alignment marks

PERIODIC MAINTENANCE AND MINOR REPAIR

EAU23022

1. Remove the cotter pin from the axle nut, and then loosen the axle nut.
2. Loosen the chain puller locknut at each end of the swingarm.
3. To tighten the drive chain, turn the adjusting nut at each end of the swingarm in direction (a). To loosen the drive chain, turn the adjusting nut at each end of the swingarm in direction (b), and then push the rear wheel forward.
4. Tighten the locknuts, and then tighten the axle nut to the specified torque.
5. Insert a new cotter pin into the axle nut, and then bend its ends as shown.

Tightening torque:

Axle nut:
90 Nm (9.0 m•kgf, 65.1 ft•lbf)

NOTE: Make sure that two notches in the axle nut are aligned with the hole through the wheel axle, otherwise further tighten the axle nut until they are.

NOTE: Using the alignment marks on each side of the swingarm, make sure that both adjusting nuts are in the same position for proper wheel alignment.

ECA10570

CAUTION:

Improper drive chain slack will overload the engine as well as other vital parts of the motorcycle and can lead to chain slippage or breakage. To prevent this from occurring, keep the drive chain slack within the specified limits.

EWA10700

WARNING

Always use a new cotter pin for the axle nut.

Cleaning and lubricating the drive chain

The drive chain must be cleaned and lubricated at the intervals specified in the periodic maintenance and lubrication chart, otherwise it will quickly wear out, especially when riding in dusty or wet areas. Service the drive chain as follows.

ECA10581

CAUTION:

The drive chain must be lubricated after washing the motorcycle and riding in the rain.

1. Clean the drive chain with kerosene and a small soft brush.

ECA11120

CAUTION:

To prevent damaging the O-rings, do not clean the drive chain with steam cleaners, high-pressure washers or inappropriate solvents.

2. Wipe the drive chain dry.
3. Thoroughly lubricate the drive chain with a special O-ring chain lubricant.

PERIODIC MAINTENANCE AND MINOR REPAIR

ECA11110

CAUTION:

Do not use engine oil or any other lubricants for the drive chain, as they may contain substances that could damage the O-rings.

EAU23100

Checking and lubricating the cables

The operation of all control cables and the condition of the cables should be checked before each ride, and the cables and cable ends should be lubricated if necessary. If a cable is damaged or does not move smoothly, have a Yamaha dealer check or replace it.

Recommended lubricant:
Engine oil

EWA10720

⚠ WARNING

Damage to the outer sheath may interfere with proper cable operation and will cause the inner cable to rust. Replace a damaged cable as soon as possible to prevent unsafe conditions.

EAU23111

Checking and lubricating the throttle grip and cable

The operation of the throttle grip should be checked before each ride. In addition, the cable should be lubricated at the intervals specified in the periodic maintenance chart.

PERIODIC MAINTENANCE AND MINOR REPAIR

EAU23120

Adjusting the Autolube pump

The Autolube pump is a vital and sophisticated component of the engine, which must be adjusted by a Yamaha dealer at the intervals specified in the periodic maintenance and lubrication chart.

EAU23131

Checking and lubricating the brake and shift pedals

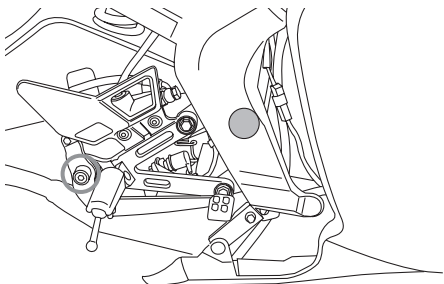
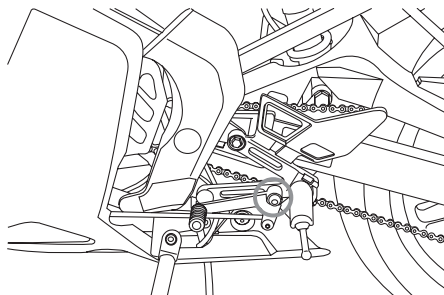

The operation of the brake and shift pedals should be checked before each ride, and the pedal pivots should be lubricated if necessary.

Recommended lubricant:

Lithium-soap-based grease (all-purpose grease)

EAU23140

Checking and lubricating the brake and clutch levers

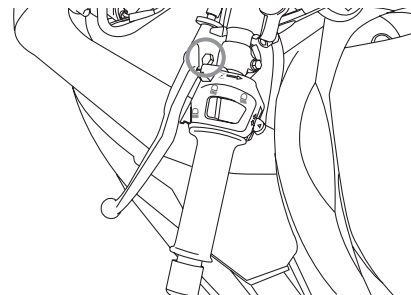
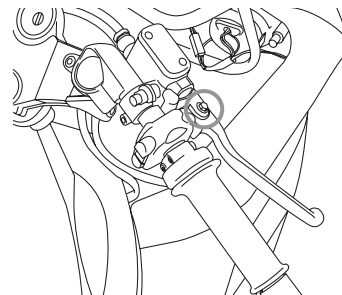

The operation of the brake and clutch levers should be checked before each ride, and the lever pivots should be lubricated if necessary.

Recommended lubricant:

Lithium-soap-based grease (all-purpose grease)

PERIODIC MAINTENANCE AND MINOR REPAIR

EAU23200

Checking and lubricating the sidestand

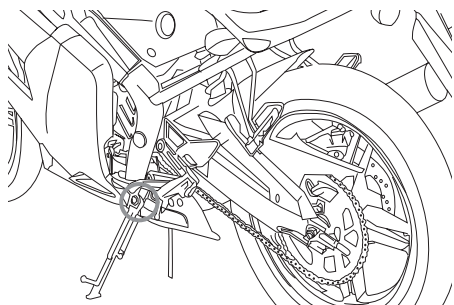

The operation of the sidestand should be checked before each ride, and the sidestand pivot and metal-to-metal contact surfaces should be lubricated if necessary.

EWA10730

⚠ WARNING

If the sidestand does not move up and down smoothly, have a Yamaha dealer check or repair it.

Recommended lubricant:

Lithium-soap-based grease (all-purpose grease)

EAU23271

Checking the front fork

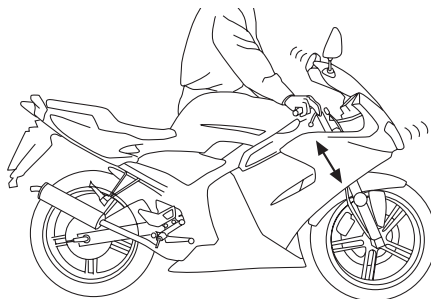

The condition and operation of the front fork must be checked as follows at the intervals specified in the periodic maintenance and lubrication chart.

To check the condition

EWA10750

⚠ WARNING

Securely support the motorcycle so that there is no danger of it falling over.

Check the inner tubes for scratches, damage and excessive oil leakage.

To check the operation

1. Place the motorcycle on a level surface and hold it in an upright position.

2. While applying the front brake, push down hard on the handlebars several times to check if the front fork compresses and rebounds smoothly.

ECA10590

CAUTION:

If any damage is found or the front fork does not operate smoothly, have a Yamaha dealer check or repair it.

PERIODIC MAINTENANCE AND MINOR REPAIR

EAU23280

Checking the steering

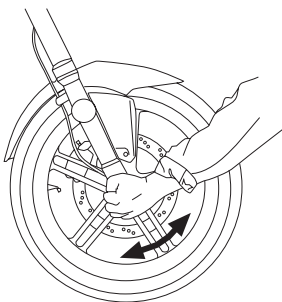

Worn or loose steering bearings may cause danger. Therefore, the operation of the steering must be checked as follows at the intervals specified in the periodic maintenance and lubrication chart.

1. Place a stand under the engine to raise the front wheel off the ground.

EWA10750

⚠ WARNING

Securely support the motorcycle so that there is no danger of it falling over.

2. Hold the lower ends of the front fork legs and try to move them forward and backward. If any free

play can be felt, have a Yamaha dealer check or repair the steering.

EAU23290

Checking the wheel bearings

The front and rear wheel bearings must be checked at the intervals specified in the periodic maintenance and lubrication chart. If there is play in the wheel hub or if the wheel does not turn smoothly, have a Yamaha dealer check the wheel bearings.

PERIODIC MAINTENANCE AND MINOR REPAIR

Battery

EAU23441

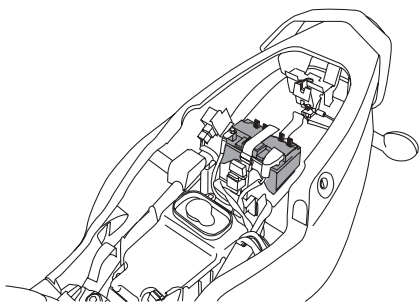

This model is equipped with a sealed-type (MF) battery, which does not require any maintenance. There is no need to check the electrolyte or to add distilled water.

To charge the battery

Have a Yamaha dealer charge the battery as soon as possible if it seems to have discharged. Keep in mind that the battery tends to discharge more quickly if the vehicle is equipped with optional electrical accessories.

EWA10760

WARNING

- **Electrolyte is poisonous and dangerous since it contains sulfuric acid, which causes**

severe burns. Avoid any contact with skin, eyes or clothing and always shield your eyes when working near batteries. In case of contact, administer the following FIRST AID.

- **EXTERNAL:** Flush with plenty of water.
- **INTERNAL:** Drink large quantities of water or milk and immediately call a physician.
- **EYES:** Flush with water for 15 minutes and seek prompt medical attention.
- **Batteries produce explosive hydrogen gas. Therefore, keep sparks, flames, cigarettes, etc., away from the battery and provide sufficient ventilation when charging it in an enclosed space.**
- **KEEP THIS AND ALL BATTERIES OUT OF THE REACH OF CHILDREN.**

To store the battery

1. If the vehicle will not be used for more than one month, remove the battery, fully charge it, and then place it in a cool, dry place.

2. If the battery will be stored for more than two months, check it at least once a month and fully charge it if necessary.
3. Fully charge the battery before installation.
4. After installation, make sure that the battery leads are properly connected to the battery terminals.

ECA10630

CAUTION:

- **Always keep the battery charged. Storing a discharged battery can cause permanent battery damage.**
- **To charge a sealed-type (MF) battery, a special (constant-voltage) battery charger is required. Using a conventional battery charger will damage the battery. If you do not have access to a sealed-type (MF) battery charger, have a Yamaha dealer charge your battery.**

PERIODIC MAINTENANCE AND MINOR REPAIR

EAU23481

Replacing the fuse

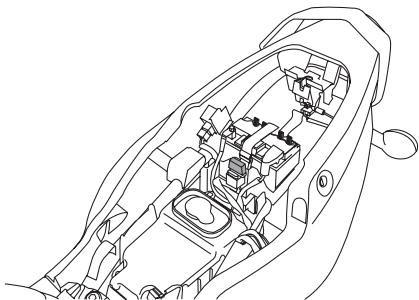

The fuse holder is located under the seat. (See page 3-9.)

If the fuse is blown, replace it as follows.

1. Turn the key to “ \otimes ” and turn off all electrical circuits.
2. Remove the blown fuse, and then install a new fuse of the specified amperage.

Specified fuse:
10 A

ECA10640

CAUTION:

Do not use a fuse of a higher amperage rating than recommended to avoid causing extensive damage to the electrical system and possibly a fire.

3. Turn the key to “O” and turn on the electrical circuits to check if the devices operate.
4. If the fuse immediately blows again, have a Yamaha dealer check the electrical system.

EAU23800

Replacing the headlight bulb

This model is equipped with a quartz bulb headlight. If the headlight bulb burns out, replace it as follows.

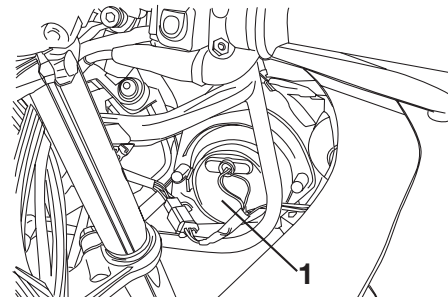

1. Headlight bulb cover

1. Remove the headlight bulb cover, and then disconnect the headlight lead connectors.

PERIODIC MAINTENANCE AND MINOR REPAIR

ECA10660

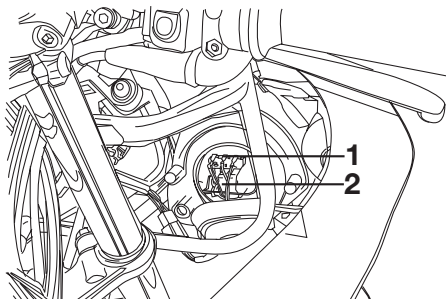

1. Headlight lead connectors
2. Headlight bulb holder

2. Unhook the headlight bulb holder, and then remove the defective bulb.

EWA10790

WARNING

Headlight bulbs get very hot. Therefore, keep flammable products away from a lit headlight bulb, and do not touch the bulb until it has cooled down.

3. Place a new headlight bulb into position, and then secure it with the bulb holder.

EAUS1150

Replacing the license plate light bulb

1. Remove the lens by removing the screw.
2. Remove the defective bulb by pulling it out.
3. Insert a new bulb into the socket.
4. Install the lens by installing the screw.

ECA11190

CAUTION:

Do not overtighten the screw, otherwise the lens may break.

CAUTION:

Do not touch the glass part of the headlight bulb to keep it free from oil, otherwise the transparency of the glass, the luminosity of the bulb, and the bulb life will be adversely affected. Thoroughly clean off any dirt and fingerprints on the headlight bulb using a cloth moistened with alcohol or thinner.

4. Connect the headlight lead connectors, and then install the bulb cover.
5. Have a Yamaha dealer adjust the headlight beam if necessary.

PERIODIC MAINTENANCE AND MINOR REPAIR

Replacing a turn signal light bulb or the tail/brake light bulb

EAU24281

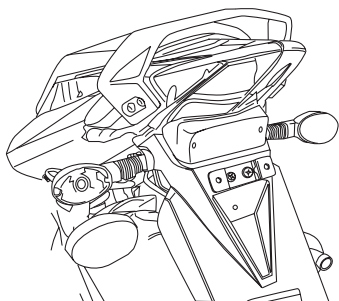
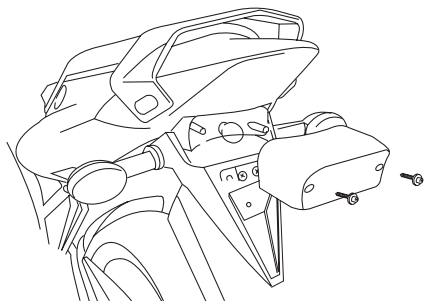

1. Remove the lens by removing the screws.
2. Remove the defective bulb by pushing it in and turning it counterclockwise.

3. Insert a new bulb into the socket, push it in, and then turn it clockwise until it stops.
4. Install the lens by installing the screws.

CAUTION:

Do not overtighten the screws, otherwise the lens may break.

ECA10680

Replacing a front turn signal light bulb

EAU1350

ECA10670

CAUTION:

It is advisable to have a Yamaha dealer perform this job.

1. Remove the socket (together with the bulb) by turning it counterclockwise for the right turn signal and turning it clockwise for the left turn signal.
2. Remove the defective bulb by pulling it out.
3. Insert a new bulb into the socket.
4. Install the socket (together with the bulb) by turning it clockwise for the right turn signal and turning it counterclockwise for the left turn signal.

EAU25870

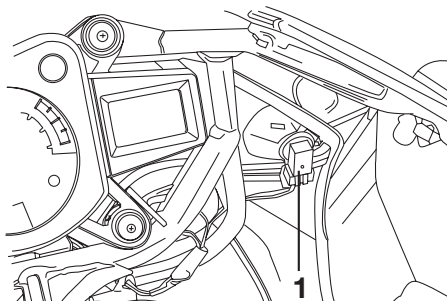

1. Socket

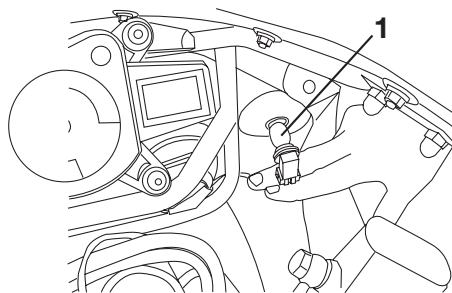

1. Bulb

Troubleshooting

Although Yamaha motorcycles receive a thorough inspection before shipment from the factory, trouble may occur during operation. Any problem in the fuel, compression, or ignition systems, for example, can cause poor starting and loss of power.

The following troubleshooting charts represent quick and easy procedures for checking these vital systems yourself. However, should your motorcycle require any repair, take it to a Yamaha dealer, whose skilled technicians have the necessary tools, experience, and know-how to service the motorcycle properly.

Use only genuine Yamaha replacement parts. Imitation parts may look like Yamaha parts, but they are often inferior, have a shorter service life and can lead to expensive repair bills.

PERIODIC MAINTENANCE AND MINOR REPAIR

EAU25921

Troubleshooting charts

Starting problems or poor engine performance

EWA10840

⚠ WARNING

Keep away open flames and do not smoke while checking or working on the fuel system.

1. Fuel

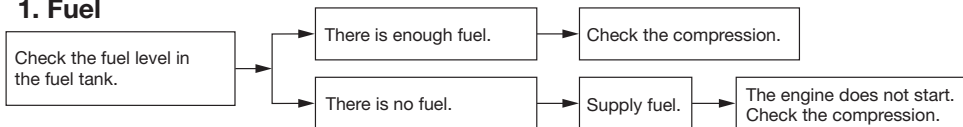

2. Compression

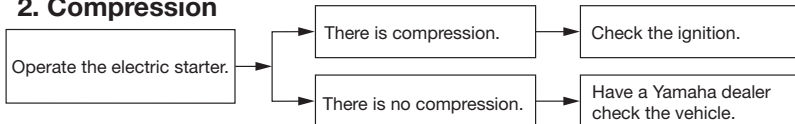

3. Ignition

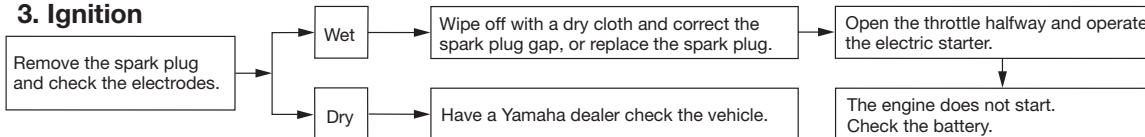

4. Battery

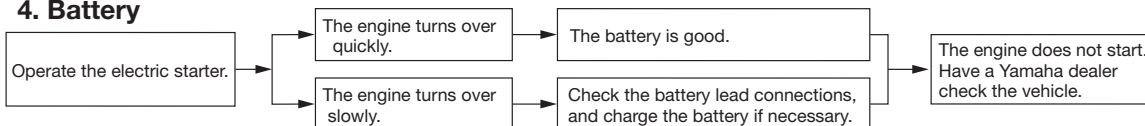

PERIODIC MAINTENANCE AND MINOR REPAIR

Engine overheating

EWA10400

⚠ WARNING

- Do not remove the radiator cap when the engine and radiator are hot. Scalding hot fluid and steam may be blown out under pressure, which could cause serious injury. Be sure to wait until the engine has cooled.
- After removing the radiator cap retaining bolt, place a thick rag, like a towel, over the radiator cap, and then slowly rotate the cap counterclockwise to the detent to allow any residual pressure to escape. When the hissing sound has stopped, press down on the cap while turning it counterclockwise, and then remove the cap.

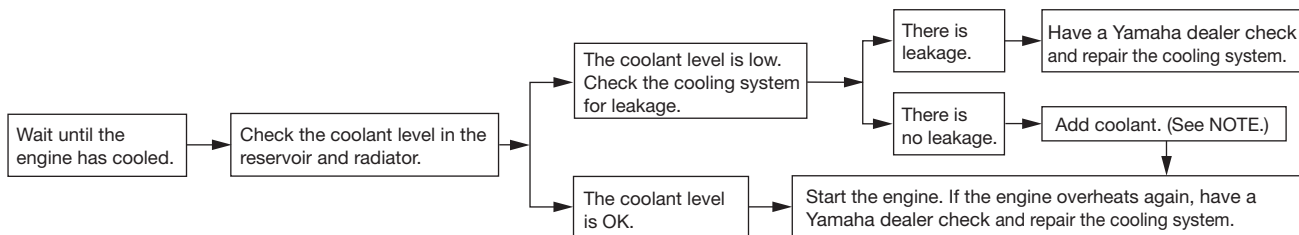

NOTE:

If coolant is not available, tap water can be temporarily used instead, provided that it is changed to the recommended coolant as soon as possible.

MOTORCYCLE CARE AND STORAGE

EAU26001

Care

While the open design of a motorcycle reveals the attractiveness of the technology, it also makes it more vulnerable. Rust and corrosion can develop even if high-quality components are used. A rusty exhaust pipe may go unnoticed on a car, however, it detracts from the overall appearance of a motorcycle. Frequent and proper care does not only comply with the terms of the warranty, but it will also keep your motorcycle looking good, extend its life and optimize its performance.

Before cleaning

1. Cover the muffler outlet with a plastic bag after the engine has cooled down.
2. Make sure that all caps and covers as well as all electrical couplers and connectors, including the spark plug cap, are tightly installed.
3. Remove extremely stubborn dirt, like oil burnt onto the crankcase, with a degreasing agent and a brush, but never apply such pro-

ducts onto seals, gaskets, sprockets, the drive chain and wheel axles. Always rinse the dirt and degreaser off with water.

Cleaning

ECA10770

CAUTION:

- **Avoid using strong acidic wheel cleaners, especially on spoked wheels. If such products are used on hard-to-remove dirt, do not leave the cleaner on the affected area any longer than instructed. Also, thoroughly rinse the area off with water, immediately dry it, and then apply a corrosion protection spray.**
- **Improper cleaning can damage windshields, cowlings, panels and other plastic parts. Use only a soft, clean cloth or sponge with mild detergent and water to clean plastic.**
- **Do not use any harsh chemical products on plastic parts. Be sure to avoid using cloths or sponges which have been in contact with strong or abrasive**

cleaning products, solvent or thinner, fuel (gasoline), rust removers or inhibitors, brake fluid, antifreeze or electrolyte.

- **Do not use high-pressure washers or steam-jet cleaners since they cause water seepage and deterioration in the following areas: seals (of wheel and swingarm bearings, fork and brakes), electric components (couplers, connectors, instruments, switches and lights), breather hoses and vents.**
 - **For motorcycles equipped with a windshield: Do not use strong cleaners or hard sponges as they will cause dulling or scratching. Some cleaning compounds for plastic may leave scratches on the windshield. Test the product on a small hidden part of the windshield to make sure that it does not leave any marks. If the windshield is scratched, use a quality plastic polishing compound after washing.**
-

MOTORCYCLE CARE AND STORAGE

After normal use

Remove dirt with warm water, a mild detergent, and a soft, clean sponge, and then rinse thoroughly with clean water. Use a toothbrush or bottle-brush for hard-to-reach areas. Stubborn dirt and insects will come off more easily if the area is covered with a wet cloth for a few minutes before cleaning.

After riding in the rain, near the sea or on salt-sprayed roads

Since sea salt or salt sprayed on roads during winter are extremely corrosive in combination with water, carry out the following steps after each ride in the rain, near the sea or on salt-sprayed roads.

NOTE: _____

Salt sprayed on roads in the winter may remain well into spring.

1. Clean the motorcycle with cold water and a mild detergent, after the engine has cooled down.

ECA10790

CAUTION: _____

Do not use warm water since it increases the corrosive action of the salt.

2. Apply a corrosion protection spray on all metal, including chrome- and nickel-plated, surfaces to prevent corrosion.

After cleaning

1. Dry the motorcycle with a chamois or an absorbing cloth.
2. Immediately dry the drive chain and lubricate it to prevent it from rusting.
3. Use a chrome polish to shine chrome, aluminum and stainless-steel parts, including the exhaust system. (Even the thermally induced discoloring of stainless-steel exhaust systems can be removed through polishing.)
4. To prevent corrosion, it is recommended to apply a corrosion protection spray on all metal, including chrome- and nickel-plated, surfaces.

5. Use spray oil as a universal cleaner to remove any remaining dirt.
6. Touch up minor paint damage caused by stones, etc.
7. Wax all painted surfaces.
8. Let the motorcycle dry completely before storing or covering it.

EWA11130

⚠ WARNING _____

- **Make sure that there is no oil or wax on the brakes or tires.**
- **If necessary, clean the brake discs and brake linings with a regular brake disc cleaner or acetone, and wash the tires with warm water and a mild detergent. Before riding at higher speeds, test the motorcycle's braking performance and cornering behavior.**

ECA10800

CAUTION: _____

- **Apply spray oil and wax sparingly and make sure to wipe off any excess.**
- **Never apply oil or wax to any rubber and plastic parts, but treat them with a suitable care product.**

MOTORCYCLE CARE AND STORAGE

- **Avoid using abrasive polishing compounds as they will wear away the paint.**
-

NOTE:

Consult a Yamaha dealer for advice on what products to use.

EAU37220

Storage Short-term

Always store your motorcycle in a cool, dry place and, if necessary, protect it against dust with a porous cover.

ECA10810

CAUTION:

- **Storing the motorcycle in a poorly ventilated room or covering it with a tarp, while it is still wet, will allow water and humidity to seep in and cause rust.**
 - **To prevent corrosion, avoid damp cellars, stables (because of the presence of ammonia) and areas where strong chemicals are stored.**
-

Long-term

Before storing your motorcycle for several months:

1. Follow all the instructions in the “Care” section of this chapter.
2. Turn the fuel cock lever to “OFF”.
3. Drain the carburetor float chamber by loosening the drain bolt; this will prevent fuel deposits

from building up. Pour the drained fuel into the fuel tank.

4. Fill up the fuel tank and add fuel stabilizer (if available) to prevent the fuel tank from rusting and the fuel from deteriorating.
5. Perform the following steps to protect the cylinder, piston rings, etc. from corrosion.
 - a. Remove the spark plug cap and spark plug.
 - b. Pour a teaspoonful of engine oil into the spark plug bore.
 - c. Install the spark plug cap onto the spark plug, and then place the spark plug on the cylinder head so that the electrodes are grounded. (This will limit sparking during the next step.)
 - d. Turn the engine over several times with the starter. (This will coat the cylinder wall with oil.)
 - e. Remove the spark plug cap from the spark plug, and then install the spark plug and the spark plug cap.

MOTORCYCLE CARE AND STORAGE

EWA10950

WARNING

To prevent damage or injury from sparking, make sure to ground the spark plug electrodes while turning the engine over.

6. Lubricate all control cables and the pivoting points of all levers and pedals as well as of the sidestand/centerstand.
7. Check and, if necessary, correct the tire air pressure, and then lift the motorcycle so that both of its wheels are off the ground. Alternatively, turn the wheels a little every month in order to prevent the tires from becoming degraded in one spot.
8. Cover the muffler outlet with a plastic bag to prevent moisture from entering it.
9. Remove the battery and fully charge it. Store it in a cool, dry place and charge it once a month. Do not store the battery in an excessively cold or warm place [less than 0 °C (30 °F) or more than 30 °C (90 °F)]. For more

information on storing the battery, see page 6-27.

NOTE: _____
Make any necessary repairs before storing the motorcycle.

SPECIFICATIONS

Dimensions

- Overall length
2202 mm (86.7 in)
- Overall width
689 mm (27.1 in)
- Overall height
1175 mm (46.3 in)
- Seat height
820 mm (32.3 in)
- Wheelbase
1341 mm (52.8 in)
- Ground clearance
151 mm (5.94 in)
- Minimum turning radius
2900 mm (114.2 in)

Weight

- With oil and fuel
124 kg (273 lb)

Engine

- Engine type
Liquid cooled 2-stroke
- Cylinder arrangement
Forward-inclined single cylinder
- Displacement
49.7 cm³ (3.03 cu*in)
- Bore x stroke
40.3 x 39.0 mm (1.58 x 1.53 in)
- Compression ratio
11.5:1
- Starting system
Electric starter
- Lubrication system
Separate lubrication (Yamaha autolube)

Oil type or grade

- Recommended engine oil grade
SAE10W30 type SE motor oil

Cooling system

- Radiator capacity (including all routes)
0.70 L (0.74 US qt) (0.62 Imp qt)
- Coolant reservoir capacity (up to the maximum level mark)
0.29L (0.31 US qt) (0.26 Imp qt)

Air filter

- Air filter element
Wet element

Recommended fuel

- Recommended fuel
Unleaded fuel
- Fuel tank capacity
13.8 L (3.65 US gal) (3.04 Imp gal)
- Fuel reserve amount
2.2 L (0.58 US gal) (0.48 Imp gal)

Carburetor

- Manufacturer
Dell'Orto
- Type x quantity
PHBN 16 x 1

Spark plug (s)

- Manufacturer/model
NGK/BR 9 ES
- Spark plug gap
0.6 ~ 0.7 mm (0.023 ~ 0.027 in)

Clutch

- Clutch type
Wet, multiple-disc

Transmission

- Primary reduction system
Helical gear
- Primary reduction ratio
71 x 20 (3.55)
- Secondary reduction system
Chain drive
- Secondary reduction ratio
60 x 11 (5.45)
- Transmission type
Constant mesh 6-speed
- Operation
Left foot operation

Gear ratio

- 1-
36 x 12 (3.00)
- 2-
33 x 16 (2.062)
- 3-
29 x 19 (1.526)
- 4-
27 x 22 (1.227)
- 5-
25 x 24 (1.041)
- 6-
24 x 25 (0.960)

Chassis

- Frame type
Double cradle
- Caster angle
25 °
- Trail
90 mm (3.54 in)

Front tire

Type
Tubeless
Size
100/80-17 52H
Manufacturer/model
Pirelli / Sport Demon
Continental/Conti-Twist SM

Rear tire

Type
Tubeless
Size
130/70-17 62H
Manufacturer/model
Pirelli / Sport Demon
Continental/Conti-Twist SM

Loading

Maximum load
196 kg (432.18 lb)
Load is total weight of the equipment, driver, passenger and accessories

Tire air pressure (measured on cold tires)

Loading condition
0-90 kg (0-198 lb)
Front
180 kPa (26 psi) (1.8 kgf/cm²)
Rear
200 kPa (28 psi) (2.0 kgf/cm²)
Loading condition
90 kg (198 lb)-Maximum load
Front
190 kPa (27 psi) (1,9 kgf/cm²)

Rear
230 kPa (33 psi) (2,3 kgf/cm²)

Front wheel

Wheel type
Cast wheel
Rim size
17 x MT2.75

Rear wheel

Wheel type
Cast wheel
Rim size
17 x MT3.50

Front brake

Type
Single disc brake
Operation
Right hand operation
Recommended fluid
DOT 4

Rear brake

Type
Single disc brake
Operation
Right foot operation
Recommended fluid
DOT 4

Front suspension

Type
Telescopic fork
Spring/shock absorber type
Coil spring/oil damper
Wheel travel
108 mm (4.25 in)

Rear suspension

Type
Unit swing
Spring/shock absorber type
Coil spring/oil damper
Wheel travel
89.2 mm (3.51 in)

Electrical system

Ignition system
MORIC
Charging system
Transistor

Battery

Manufacturer/model
TIAJIN TONG YEE INDUSTRIAL
CO. LTD. / GS GT4L-BS
Voltage, capacity
12V-3Ah

Bulb voltage, wattage x quantity

Headlight
12 V, 25.0 W / 25.0 W x 2
Tail/brake light
12 V, 21.0 W / 5.0 W x 2
Front turn signal light
12 V, 16.0 W x 2
Rear turn signal light
12 V, 10.0 W x 2
License plate light
12 V, 5.0 W x 1
Meter lighting
LED
High beam Indicator light
LED
Turn signal indicator light

SPECIFICATIONS

LED

Engine trouble warning light

LED

2-stroke oil warning light

LED

Fuses

Main fuse

10 A

EAU26351

EAU26381

EAU26400

Identification numbers

Record the key identification number, vehicle identification number and model label information in the spaces provided below for assistance when ordering spare parts from a Yamaha dealer or for reference in case the vehicle is stolen.

KEY IDENTIFICATION NUMBER:

VEHICLE IDENTIFICATION NUMBER:

MODEL LABEL INFORMATION:

Key identification number

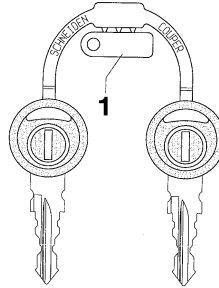

1. Key identification number

The key identification number is stamped into the key tag. Record this number in the space provided and use it for reference when ordering a new key.

Vehicle identification number

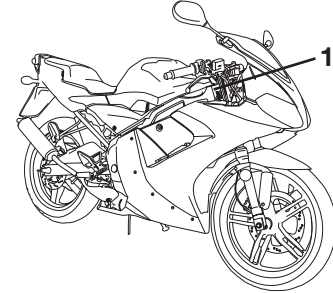

1. Vehicle identification number

The vehicle identification number is stamped into the steering head pipe. Record this number in the space provided.

NOTE: _____

The vehicle identification number is used to identify your motorcycle and may be used to register your motorcycle with the licensing authority in your area.

CONSUMER INFORMATION

EAU26480

Model label

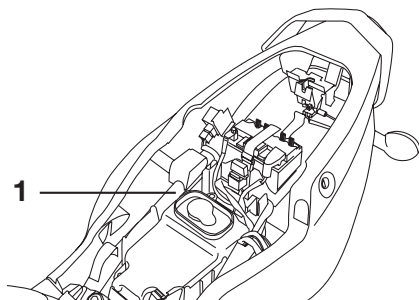

1. Model label

The model label is affixed to the frame under the seat. (See page 3-9.) Record the information on this label in the space provided. This information will be needed when ordering spare parts from a Yamaha dealer.

- 2-stroke engine oil3-7
- A**
- Air filter element6-12
 - Anti-theft device housing3-9
 - Autolube pump, adjusting6-24
- B**
- Battery6-27
 - Brake and clutch levers, checking and lubricating6-24
 - Brake and shift pedals, checking and lubricating6-24
 - Brake fluid level, checking6-19
 - Brake fluid, changing6-20
 - Brake lever3-5
 - Brake pedal3-5
 - Brake pedal free play, adjusting6-17
- C**
- Cables, checking and lubricating6-23
 - Carburetor, adjusting6-12
 - Care7-1
 - Catalytic converter3-6
 - Clutch lever3-4
 - Clutch lever free play, adjusting6-16
 - Coolant6-9
 - Coolant temperature warning light3-2
 - Cowlings and panels, removing and installing6-5
- D**
- Dimmer switch3-3
 - Drive chain slack6-21
 - Drive chain, cleaning and lubricating6-22
- E**
- Engine break-in5-3
 - Engine idling speed6-13
 - Engine stop switch3-3
 - Engine trouble warning light3-2
 - Engine, starting a warm5-2
- F**
- Front and rear brake pads, checking6-18
 - Front brake lever free play, checking6-17
 - Front fork, checking6-25
 - Fuel3-5
 - Fuel cock3-8
 - Fuel consumption, tips for reducing5-3
 - Fuel tank breather/overflow hose3-7
 - Fuel tank cap3-6
 - Fuse, replacing6-28
- H**
- Handlebar switches3-3
 - Headlight bulb, replacing6-28
 - Horn switch3-3
- I**
- Identification numbers9-1
 - Ignition circuit cut-off system3-10
 - Indicator and warning lights3-1
- K**
- Key identification number9-1
- L**
- License plate light bulb, replacing6-29
- M**
- Main switch/steering lock3-1
 - Model label9-2
- N**
- Neutral indicator light3-1
- O**
- Oil level warning light3-2
- P**
- Parking5-4
 - Part locations2-1
 - Pass switch3-3
 - Periodic maintenance and lubrication chart6-2
 - Pre-operation check list4-2
- R**
- Rear brake light switch, adjusting6-18
 - Rear view mirrors3-9
- S**
- Safety information1-1
 - Seat3-9
 - Shift pedal3-4
 - Shift pedal position, adjusting6-18
 - Shifting5-2
 - Sidestand3-10
 - Sidestand, checking and lubricating6-25
 - Spark plug, checking6-7
 - Specifications8-1
 - Speedometer unit3-2
 - Start switch3-4
 - Starter (choke) lever3-8
 - Starting a cold engine5-1
 - Steering, checking6-26
 - Storage7-3
- T**
- Tachometer3-3
 - Throttle cable free play, adjusting6-12
 - Throttle grip and cable, checking and lubricating6-23
 - Tires6-14
 - Tool kit6-1
 - Transmission oil6-8

INDEX

Troubleshooting	6-31
Troubleshooting charts	6-32
Turn signal indicator light.....	3-1
Turn signal light bulb (front), replacing	6-30
Turn signal light bulb or tail/brake light bulb, replacing	6-30
Turn signal switch	3-3

V

Vehicle identification number.....	9-1
------------------------------------	-----

W

Wheel bearings, checking.....	6-26
Wheels	6-16



PRINTED IN NEEDEERLAND
2006.10
(E)